



ŞEBEKEDEN BAĞIMSIZ  
YEDEKLEME VE  
ADA SİSTEMLERİ



**victron energy**  
BLUE POWER



ENERJİ, HER ZAMAN, HER YERDE



## INDEX

EasySolar 12V ve 24V: tam kapsamlı güneş enerjisi çözümü	4
Giriş	6
Uygulama örnekleri	7
Wapserveen.com: sustainable and eco-friendly	8
Off-grid apartments in The Philippines	10
Hospital	10
Caribbean Off-Grid Solar System: Vader Piet Windpark	12
DC sistemleri	14
AC sistemleri	17
Daha fazla yenilenebilir enerji kaynağı ekleme	20
Aksesuarlar	21
Daha fazla güç	22
Teknik bilgiler	25
Victron Energy hakkında	90





**EasySolar: Tam kapsamlı güneş enerjisi çözümü**

EasySolar, ultra hızlı bir BlueSolar şarj kontrol ünitesini (MPPT), invertör/şarj cihazı ve AC dağıtım panosunu tam kapsamlı bir çözüm halinde birleştirerek enerji çözümlerini bir adım ileriye taşımaktadır. Kablo miktarındaki önemli azalma ile EasySolar maksimum bir yatırım getirisi ile birlikte kullanım kolaylığı sağlamaktadır. 24V modelini kullanırken 1400 Watt'a kadar güneş enerjisini ve 1600VA sürekli invertör gücünü kullanmak mümkündür, hatta 3000 Watt'lık pik güçler bile sorunsuz bir şekilde kullanılabilir.

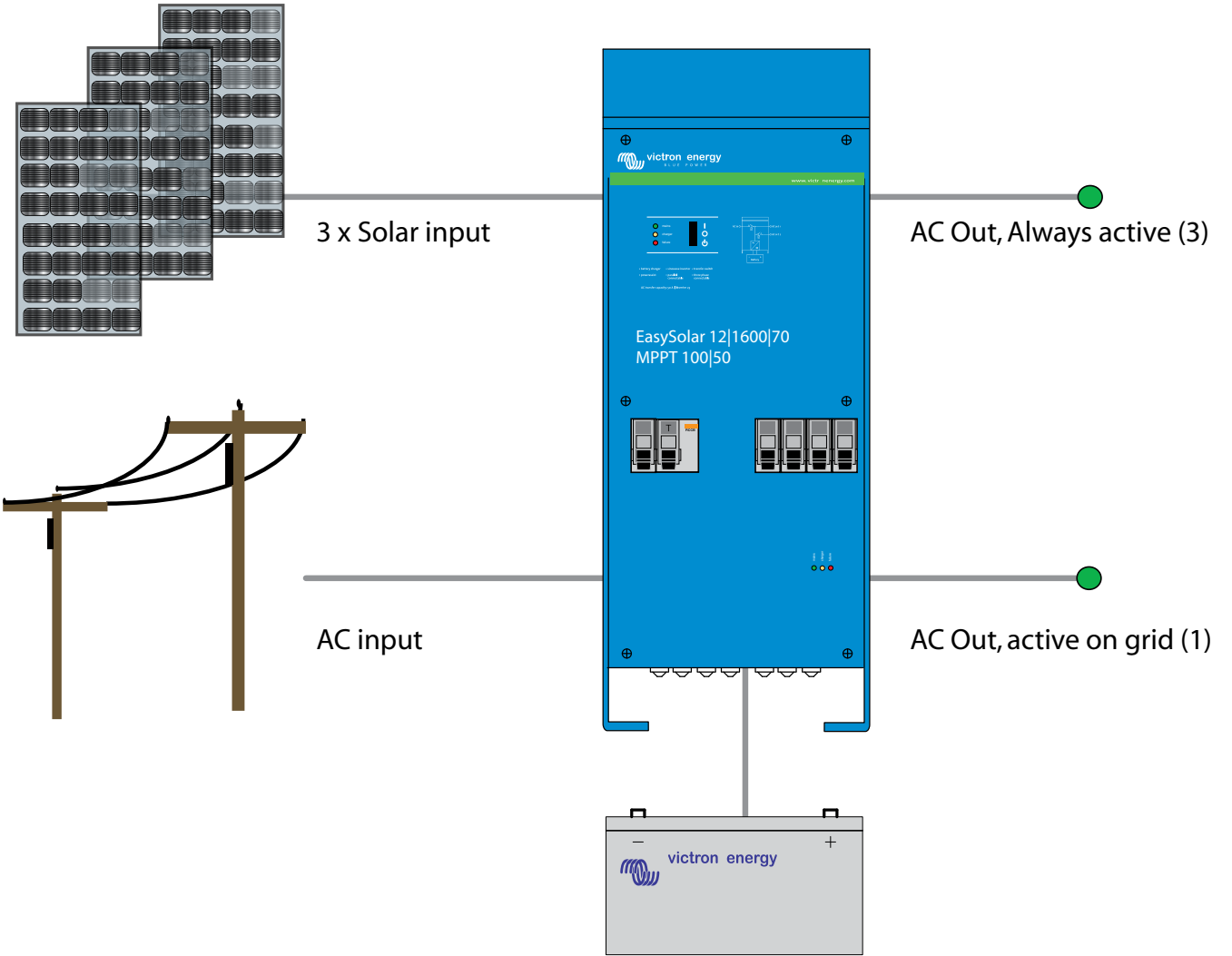
**Güneş enerjisi şarj kontrol ünitesi: BlueSolar MPPT 100/50**

PV panellerinin üç şeridi MC4 (PV-ST01) üç dizi PV konnektörleri ile bağlanabilir. Etkili enerji dağıtımı garanti edilmektedir.

**1600 VA sürekli invertör gücünü sağlayan invertör/şarj cihazı**

MPPT şarj kontrol ünitesi ve invertör/şarj cihazı DC akü kablolarını paylaşmaktadır, bu sayede ek bir kablolamaya ihtiyaç duyulmamaktadır. Aküler, güneş enerjisi (BlueSolar MPPT) ve/veya AC gücü (invertör/şarj cihazı) ile elektrik şebekesi veya bir jeneratör düzeneğinden şarj edilebilir. Elektrikli cihazlar için güneş yeterli enerjiyi sağlamıyor olsa bile tüketicilere daima enerji garantisi verilmektedir.



EasySolar 12V ve 24V: tam kapsamlı güneş enerjisi çözümü

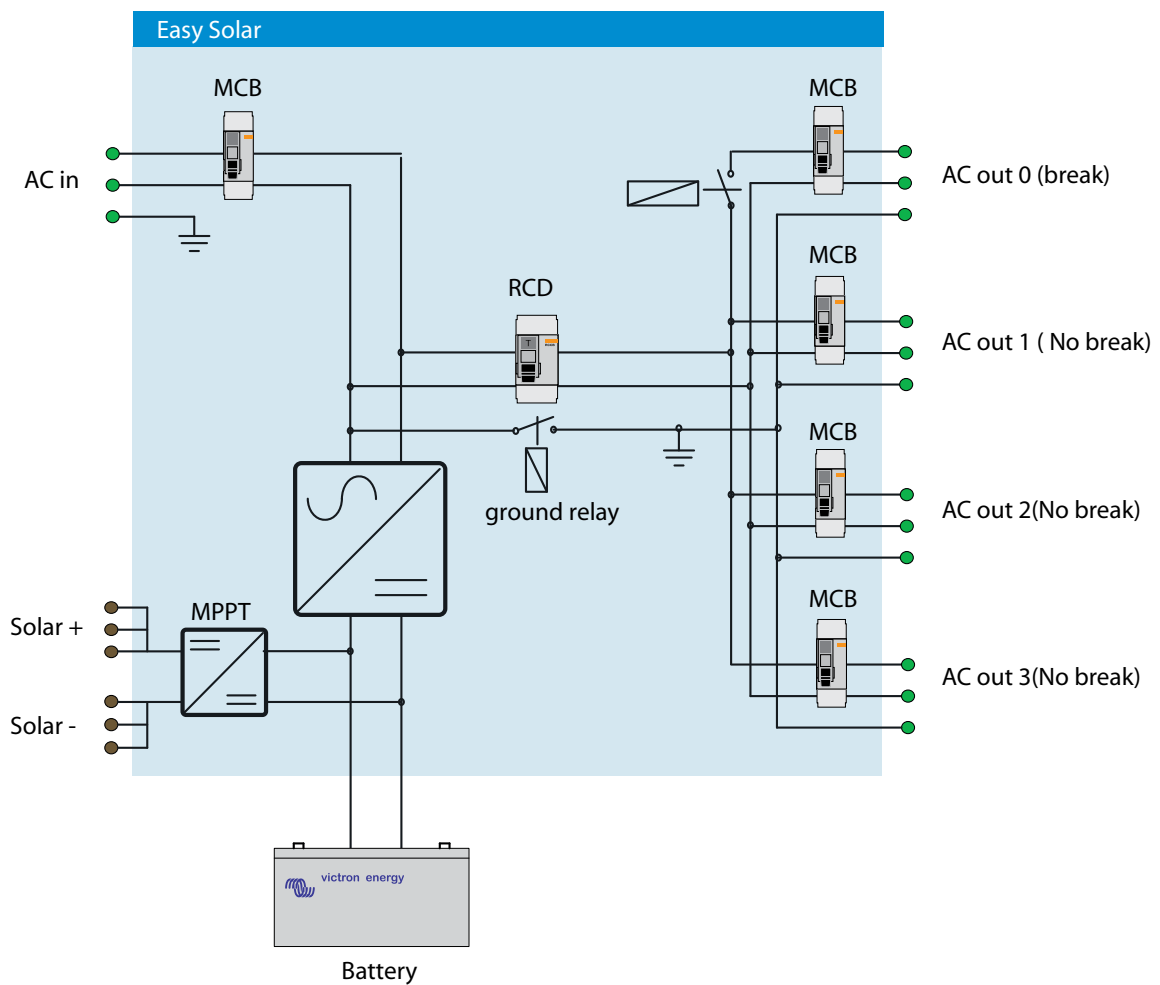
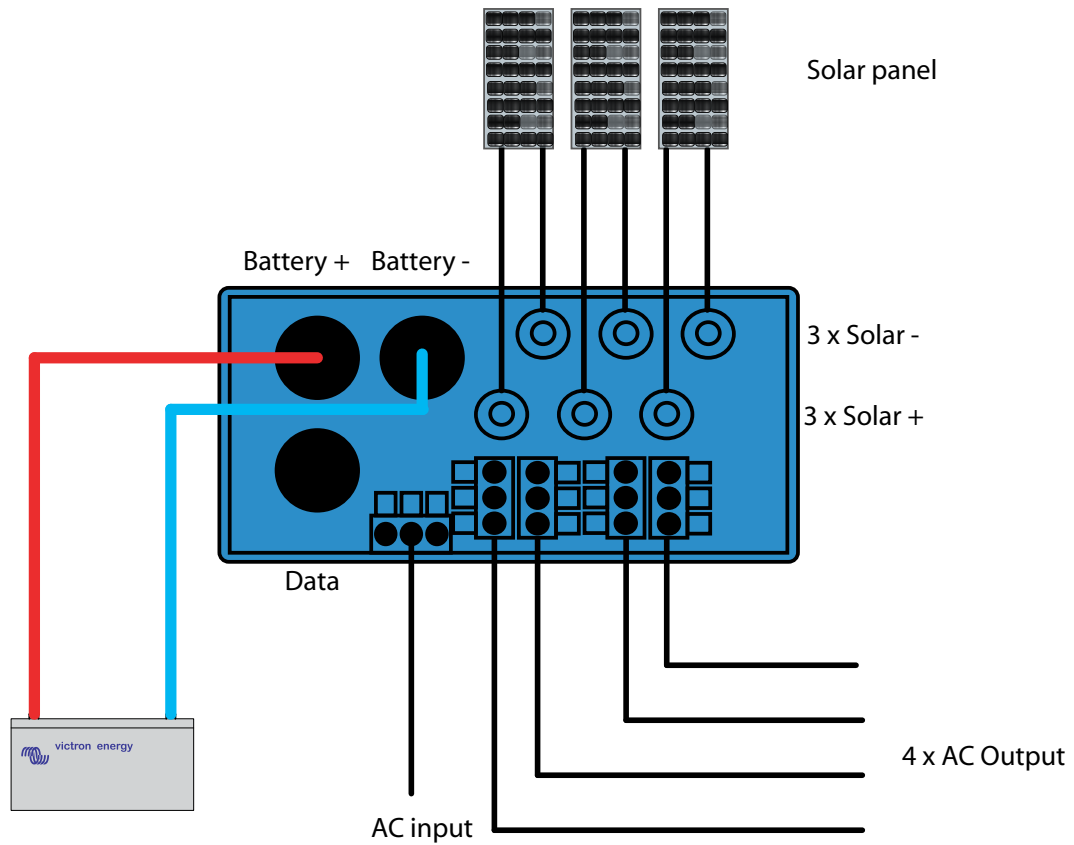





### Şebekeden bağımsız

İşlevsel bir elektrik şebekesinin varlığı her zaman görüldüğü kadar bariz değildir. Güvenilmez bir şebekenin nedeni genellikle yetersiz bir altyapıdır. Hiç şebeke yoksa işler daha da zorlaşır. Ancak yine de güvenilir bir elektrik kaynağına ihtiyaç duyulur. Bu noktada tek cevap yerel ve doğru bir şekilde çalışan bir sistemdir. Victron Energy size bu cevabı sunuyor. Özgürlük ve bağımsızlığın modern tercümesini size sunmaktan gurur duyuyoruz.

### Hibrit sistemler

Kullanılabilir tek enerji kaynağı güneşe, çözüm basit. Enerji talebinizi karşılamak için bir güneş sistemi tercih edeceksiniz. Eğer daha fazla kaynak kullanılabilirse, bunlar da güneş sisteminizi destekleyebilir. Güneş enerji talebinizi tamamen karşılayamadığı için bir güneş sistemi genellikle bir jeneratörle veya bir rüzgar jeneratörüyle desteklenir. Bu enerji kaynakları güneş açığının karşılanmasını.







Fener



Hospital



Kullanıma hazır şebeke ünitesi





### Wapserveen.com

Wapserveen.com was founded in 2004 in the town of the same name in the Dutch province of Drenthe. Its owners, Jan Blok and Angelique Schipper-Blok, started the business as a dairy farm. Later, the business was expanded to include earthquake-resistant log houses, beekeeping activities, bed & breakfast accommodation, a studio and free-range cattle. Sustainable and eco-friendly business practices come first and foremost at Wapserveen.com, so it was decided to install an off-grid system supplied by Victron Energy.

### Sustainable and eco-friendly business

Wapserveen.com has adopted sustainable and environmentally-friendly practices in a wide number of areas, both business-wise and in its day-to-day activities. Timber used to build the log houses has been sourced from sustainable forests, for example: for each tree cut down, 4 new ones have been planted. The house uses an organic stove and there is also an on-site water-pump. In addition, the business and the living quarters run on green energy generated by solar panels.

### Solar power

There are 544 solar panels on the roof at Wapserveen.com, 120 of which are connected to the off-grid system supplied by Victron Energy. The energy generated by the other 424 panels is fed into the national grid by means of a transformer connected to the transmission network.

### How the system works

The batteries are charged during the day by means of solar energy. If the solar panels are still generating energy when the batteries have been fully charged, this surplus electricity is fed back into the national grid.

This means that the batteries are always fully charged so that these can be put to use at night-time. In the summer, when there is adequate solar energy, the business can run up to 3 weeks at a time without recourse to the national grid. If there is too little sun to power the batteries, which is more likely in the winter months, the system can tap into the national grid to recharge the batteries. The system is also connected to a generator so that it's possible to operate independently from the energy provider.





### Consumers

The biggest consumer of electricity is the dairy farm. Here, use is made of equipment which must be available day and night and which is unable to operate without electricity, such as a cooling system, milking machine, vacuum pump (3kW), high-voltage motors (1kW) and lighting. Furthermore, electricity from the batteries is used to power household appliances, such as the dishwasher, washing machine, drier and the lighting.

Last but not least, Wapserveen.com supplies the nearby Johannes Post barracks with green energy. The barracks use energy so that daily activities of its military personnel can be performed.



### Victron Energy system

3 x 48V 10kVA Quattro transformer/battery chargers

24 x 2V OpzS 1520Ah in a 48-volt battery bank

1 x BMV 700 battery monitor

1 x Color Control GX

1 x 48V Skylla charger

More information about Wapserveen.com:

[www.wapserveen.com](http://www.wapserveen.com)

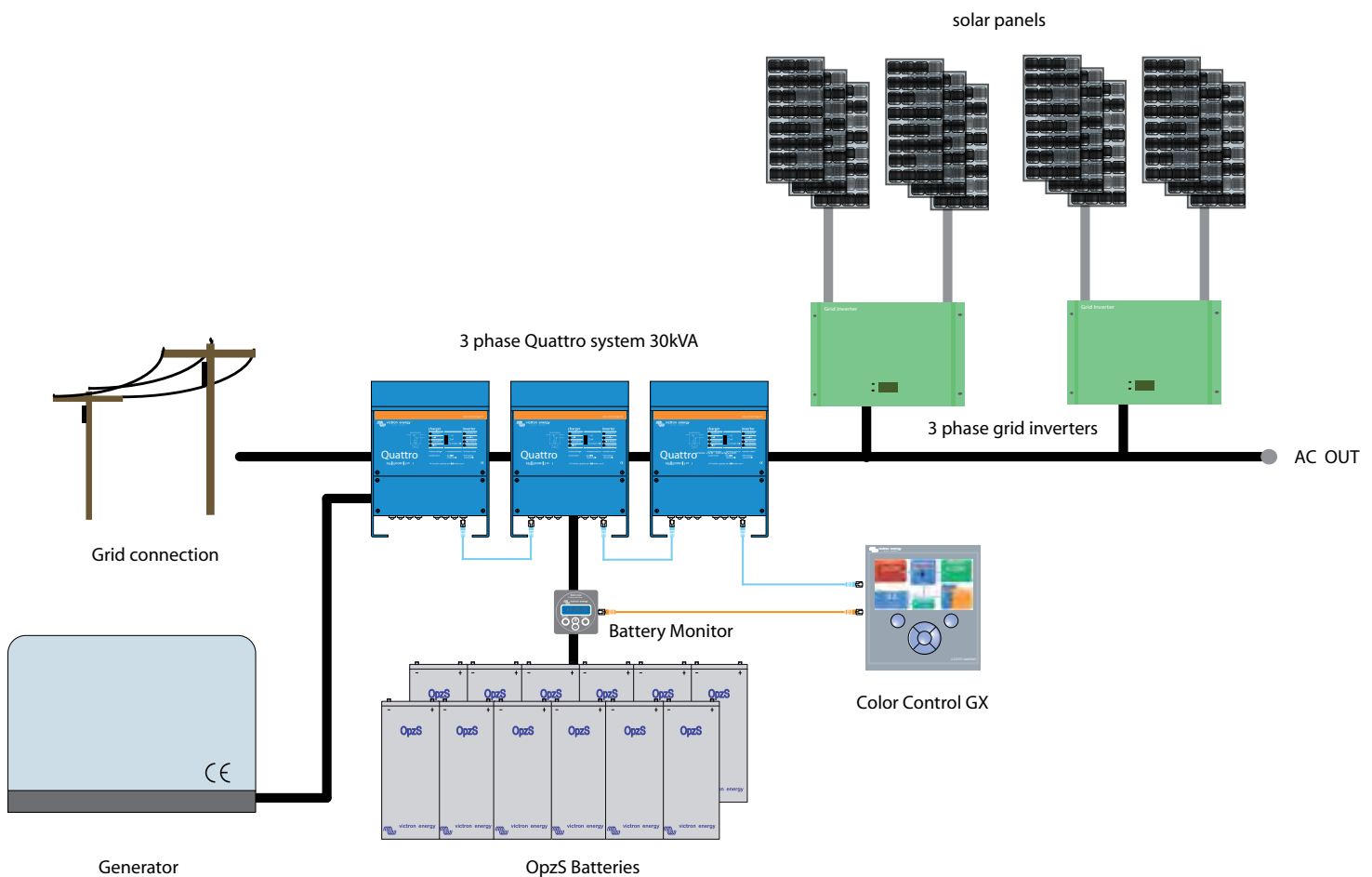



### New build apartments powered by Victron Energy

Victron Energy is powering two new build apartments for Montani Beach Resort in Sabang Puerto Galera, with an off-grid solar system. The development has LED lighting throughout, with timers for the common lighting areas. Apartments also have eco-friendly inverter type refrigerators, ceiling fans and televisions.

All loads, including the water pumps, are connected to the solar system with the exception of the air conditioning. A 4.5kWp solar array is connected to the powerful Victron Energy 150V/85A MPPT solar charge controller which charges the 48V/200Ah Lithium battery bank. The total energy storage for each apartment is 10kWh. The average electricity generated and stored is forecast to be 16-24kWh per day. This is enough to keep the batteries charged and to cover the daily loads, even when the weather conditions are not optimal. A Victron 48V/5000VA Quattro inverter/charger supplies electricity for two apartments. The AC 1 line is connected to the grid. At the moment the system is using a virtual switch with the dedicated ignore AC input option, but when grid metering

becomes available, the system can be upgraded to a HUB1 system and the excess electricity can then be fed back to the grid.

A BMV-702 battery monitor and a Color Control GX monitors the system which can also be tracked online via the VRM (Victron Remote Management) website.

The design and installation of the system is a collaboration between the distributor, PhilSolar Equipment and Trading and the local dealer/installer, Paica Off-grid Energy.





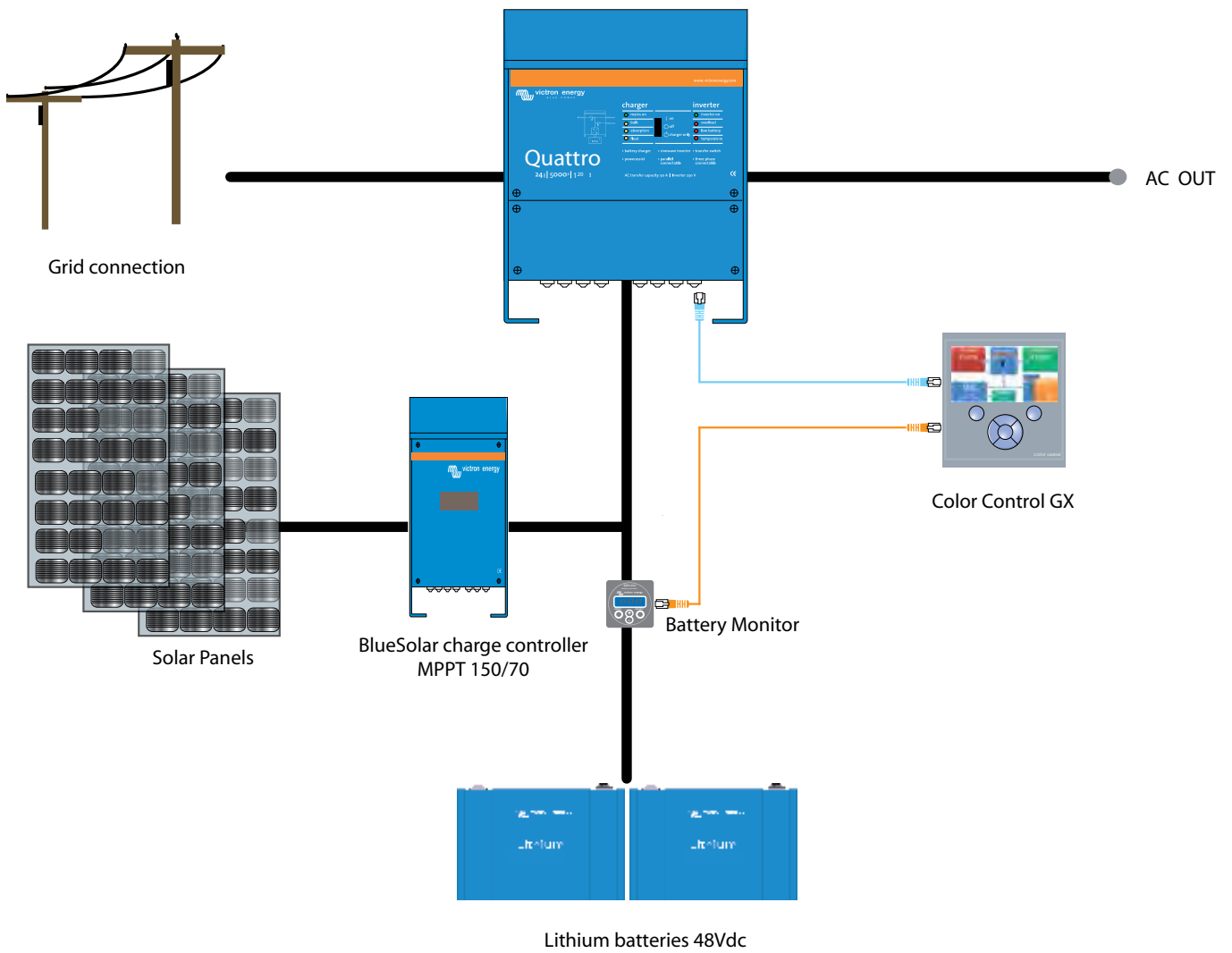



### The Vader Piet Windpark

The Vader Piet Windpark is situated on the island of Aruba, which makes up one of the four constituent countries that form the Kingdom of the Netherlands. Aruba is located 15 miles north of Venezuela in the warm waters of the southern Caribbean.

### Solar solution

Recently, Rob Fijn got in touch to update us on this solar project after its initial year in operation.

But why you may ask was an off-grid solar system required in a windpark in the first place? Two years ago Imtech Marine Curacao NV received a request to provide a solution for an off-grid solar installation for NuCapital, to support the windpark onsite maintenance team working on the 10 x 3.0 MW Vestas V-90 turbines. The turbines have been operational since December 31, 2009, but the maintenance team office and workshop had no grid connection and it was too far away from any other grid supply. A solar solution was clearly the best option, plus the existing generator could provide back-up for the proposed solar system.



### Design brief

The electricity supply requirements were for:

- An office/workshop with 3 split air conditioning units, fridge, microwave, coffee machine, printer plus small hand tools
- Office work to be carried out mainly in the daytime
- At night, batteries will be required for the lighting, fridge and one or possibly two air conditioning units
- This is also to ensure that the day time maintenance crew have cool drinks and ice, as the temperatures inside the wind turbines can reach 45 °C at 10:00 am

### Equipment specified

In considering the above, 80m<sup>2</sup> of solar panels were specified and fitted to a sloping roof, as shown in the headline image above. The full list of equipment used is:

- 40 x 280W-24V BlueSolar Polycrystalline panels
- 4 x BlueSolar MPPT 150/70 Charge controllers
- 3 x Quattro 120/5000/70 (3-phase) Inverter/Charger
- 16 x 12 Volt/220Ah Victron Energy Deep Cycle GEL batteries
- 1 x BMV-600s series battery monitor
- 1 x Color Control GX for local and remote system monitoring

### GEL Battery installation

Turbine maintenance requires the use of electronics that must be stored in a controlled climate. The room for this proved to be a perfect location for the GEL batteries, as a split unit inverter air conditioning unit maintains the room at a constant 24 °C, which is a perfect temperature to maintain 100% battery capacity.



### MPPT & Quattro installation

The 4 MPPTs are shown at the top of the photograph (at the right) with the DC break switches next to them. The DC voltage positive and negative is shown in the center of the photograph, with the take off to the left going to the batteries, which are behind the partition wall.



The DC supply then goes to 3 Quattros shown at the bottom of the photograph at the right. The Quattros are connected together to provide 3-phase 120V/60Hz.

### Victron Remote Management

The Victron Remote Management (VRM) online monitoring portal has proved to be perfect for the customer, plus nothing goes unnoticed. For example, a company installed a new air conditioning unit for the office and this was noticed immediately via the VRM, as L3 showed there was negative power on that line of -93 Watts outside working hours. The air conditioning company were recalled, the problem explained and corrected. Just one of the benefits of 24/7 remote monitoring.

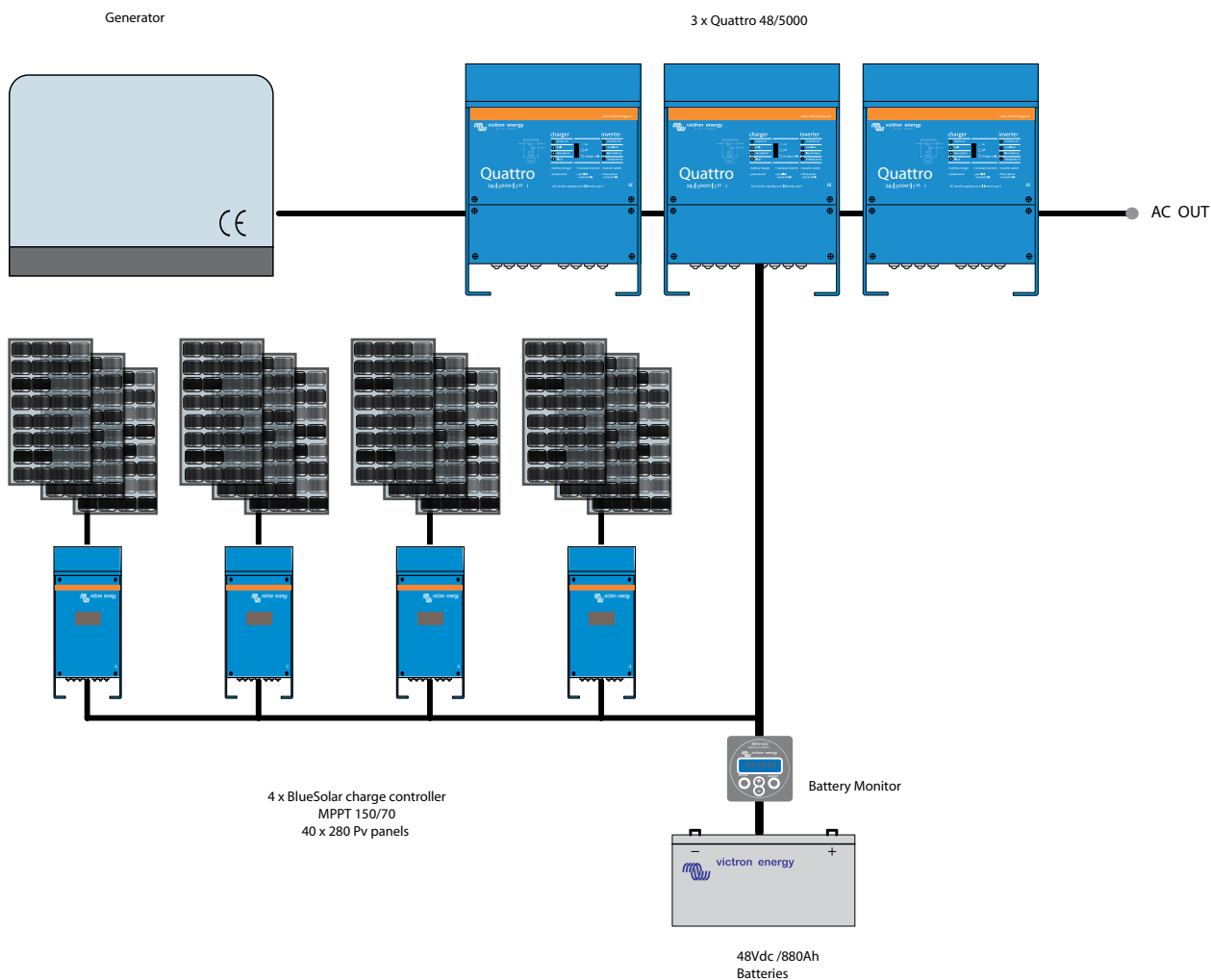



### DC Sistemleri

DC sistemlerinde, güneş enerjisi regüle edilmiş DC'ye dönüştürülür. Sonuç olarak, regüle edilmiş DC aküler ve tüketicilere sağlanır. Bir invertör DC sistemine bağlı AC tüketicilerine güç sağlar. DC sistemlerinin aksine, güneş enerjisi AC sistemlerinde doğrudan AC'ye dönüştürülür.

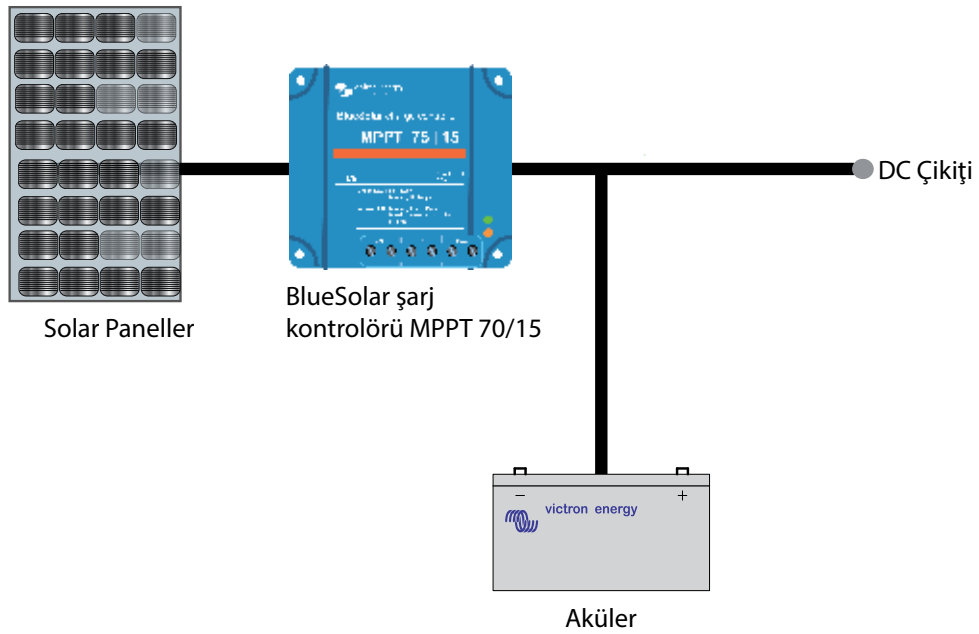

### 1. DC tüketicileri

Bir güneş paneli pratikte tüketicilere doğrudan güç sağlar. Panel ile güç tüketicisi arasındaki tek madde şarj kontrol birimidir. Bu Blue Solar Şarj Kontrol Birimi tüketiciler ve aküler için voltajları kontrol eder. DC tüketicileri doğrudan akülere bağlıdır.



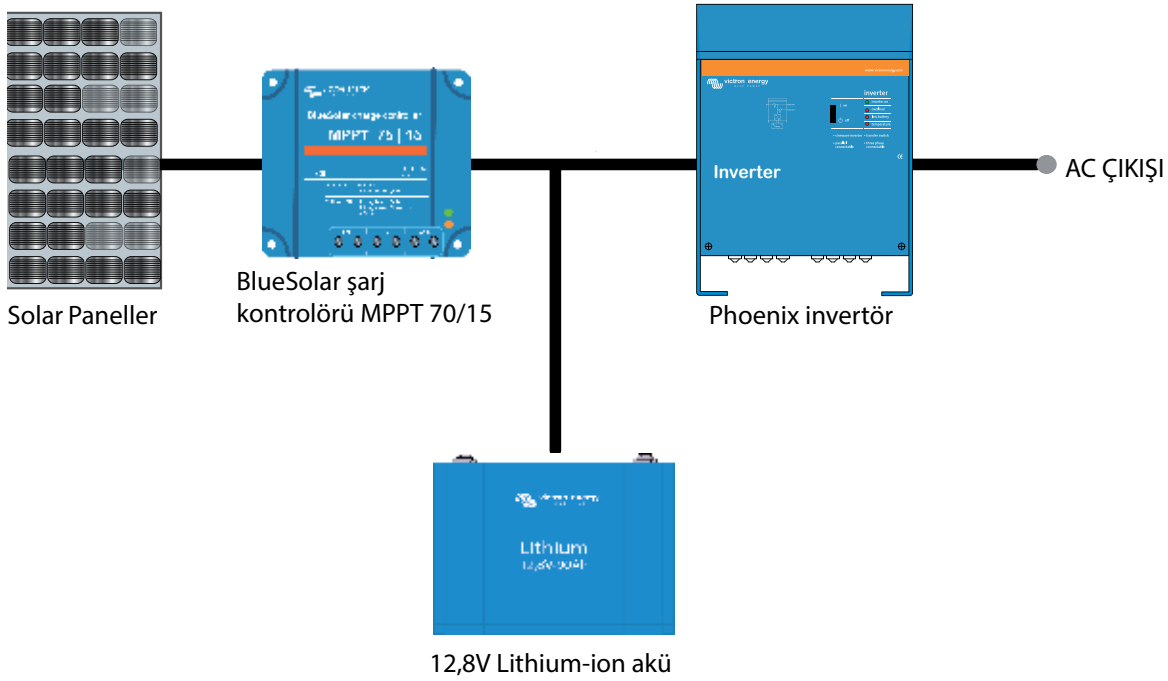

## 2. AC tüketicileri

Bu AC tüketicilerine yönelik 230 Volt çıkışa sahip bir DC sistemdir. Yukarıdaki örnekte, AC çıkışı sağlamak için bir Victron Phoenix invertör eklenir.

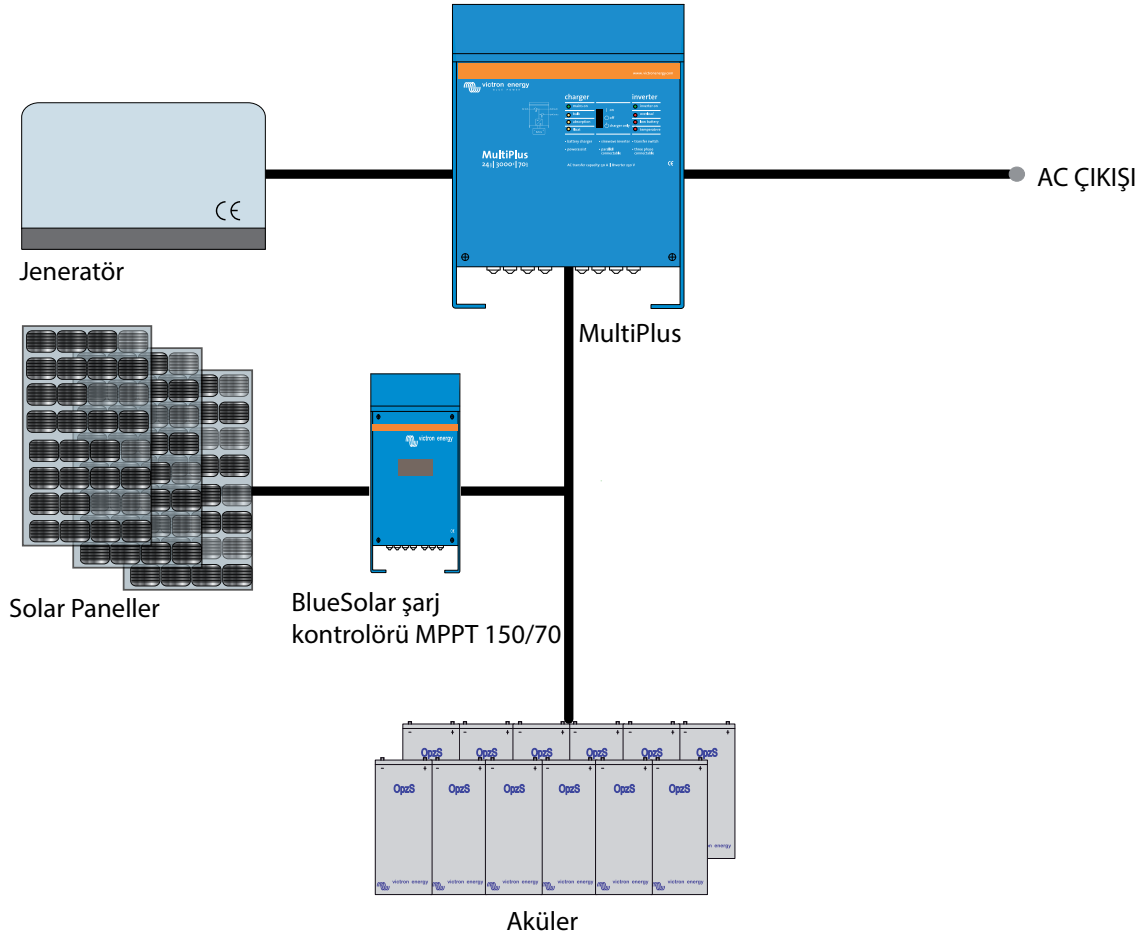

## 3. Yeterli güneş mevcut değil – hibrit güç

Güneş yeterli enerji sağlamıyorsa, sisteme bir jeneratör eklenir. Bu durumda, bir invertör yerine bir Multiplus invertör/şarj cihazı kullanılır. Jeneratör doğrudan MultiPlus'a bağlıdır. MultiPlus solar güç kullanımını en üst seviyeye çıkarıp uzun bir akü ömrü sağlarken, otomatik olarak jeneratörün çalışmasını ve durmasını düzenler.

### PowerAssist – şebeke veya jeneratör gücünün kapasitesini yükseltir

Bu benzersiz Victron özelliği MultiPlus'ın şebeke veya jeneratör gücü kapasitesine ilave yapmayı sağlar. Pik gücün genellikle sadece sınırlı bir süre için gerektiği durumlarda, MultiPlus yetersiz kıyı veya jeneratör gücünün derhal aküden alınan güçle telafi edilmesini sağlar. Yük azaldığında, akü şarj ünitesini yeniden şarj etmek için yedek güç kullanılır. Dolayısıyla, maksimum pik yükte bir jeneratörü boyundandırmak gerekmez. Bunun yerine en etkin boyutta jeneratörü kullanın.

**Not:** Bu özellik hem MultiPlus'ta hem de Quattro'da mevcuttur.

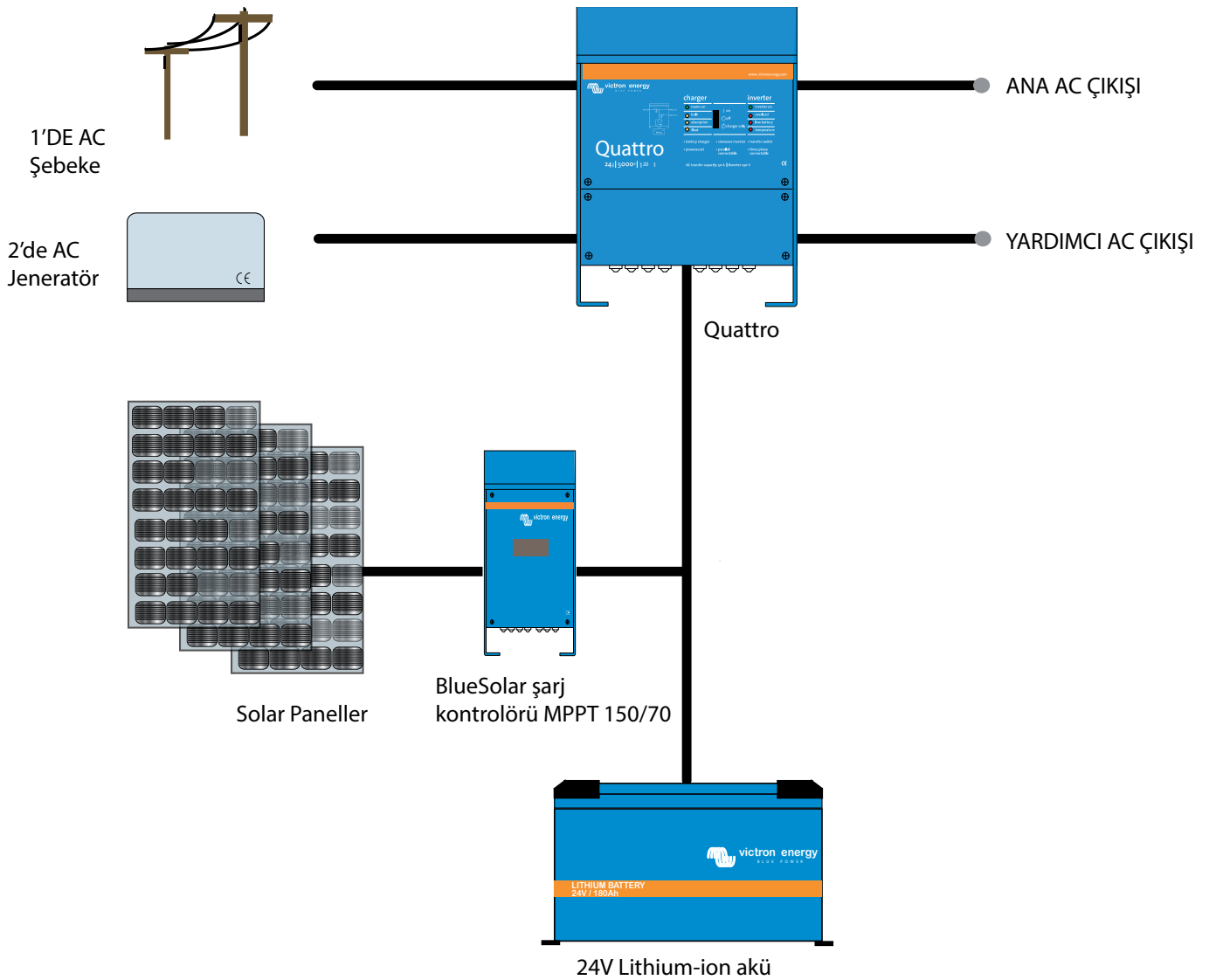

#### 4. Yedek sistem

Solar enerji bir şebeke bağlantısıyla da kombine edilebilir. Ancak yetersiz bir solar kaynakla birlikte güç kesintileri yaşayan bir şebeke bir jeneratör desteğine ihtiyaç duyar. Bir MultiPlus yerine size hem şebekeye hem de jeneratöre bağlamak için tümleşik bir aktarma anahtarına sahip bir MultiPlus olan Quattro'yu öneririz. Bu şebeke ile jeneratör arasındaki anahtarlama işlemini tamamen otomatik hale getirir.



### AC Sistemleri

Genellikle AC tüketicilerine güç sağlayan daha büyük solar sistemler için, solar gücü derhal AC'ye dönüştürmek daha verimlidir. Bu nedenle bunlara "AC sistemleri" denir. AC sistemleri DC sistemlerine kıyasla daha yüksek bir enerji verimliliğine sahiptir. BlueSolar Şebeke İnvörtörü solar enerjiyi doğrudan AC'ye dönüştürür. Bu invörtör bir MultiPlus veya Quattro tarafından sağlanan bir "şebekeye" ihtiyaç duyar. AC tüketicileri tarafından kullanılmayan solar güç fazlası aküleri şarj etmek için kullanılır.

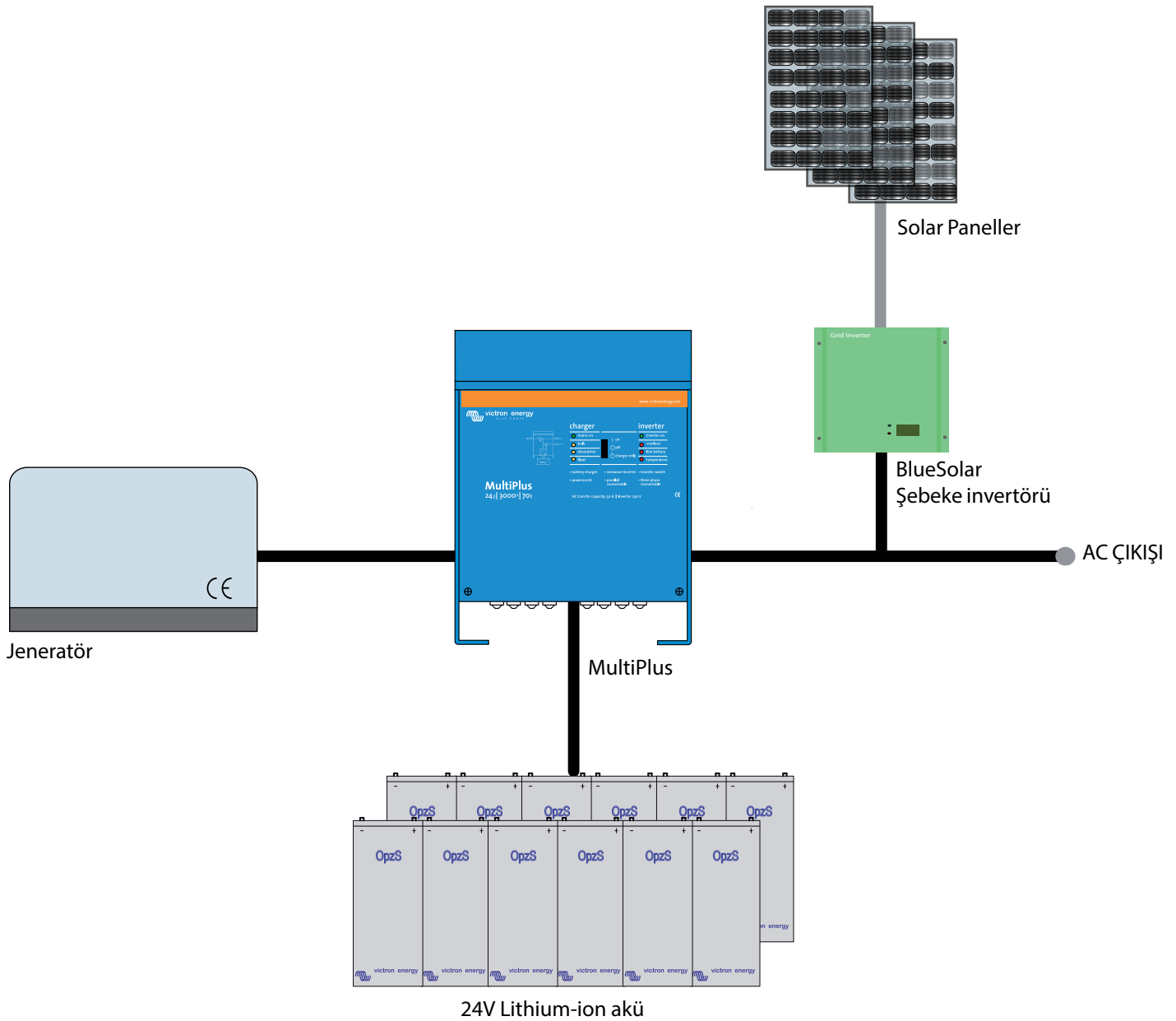

### 1. Jeneratörlü ada sistemi

Enerji solar paneller tarafından toplanır toplanmaz, Blue Solar Şebeke İnvörtörü tarafından AC'ye dönüştürülür. Jeneratör alternatif akımını doğrudan MultiPlus invörtör/şarj cihazına sağlar. MultiPlus solar güç kullanımını en üst seviyeye çıkarırken jeneratörü otomatik olarak çalıştırıp durduracaktır.

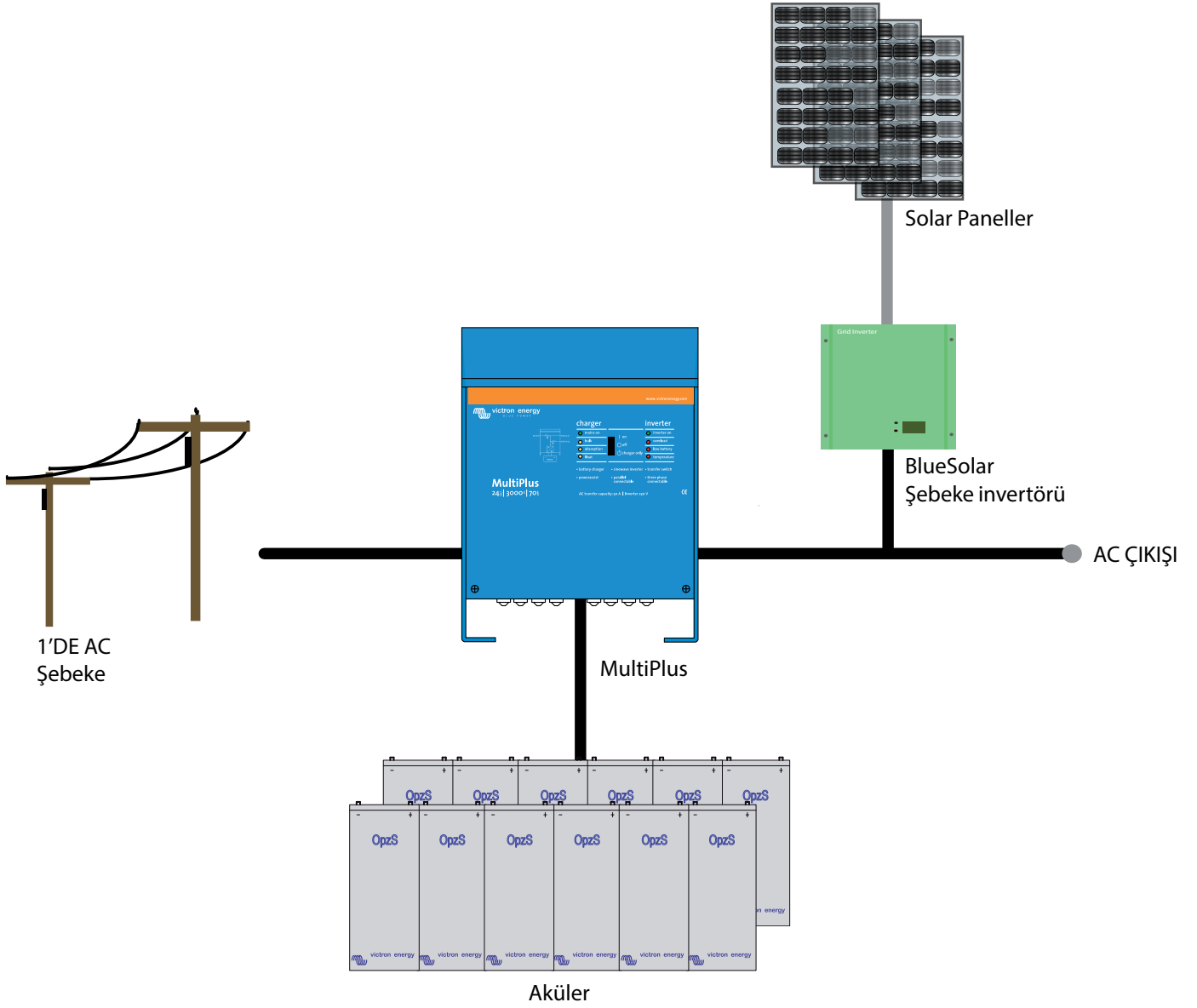

## 2. Solar ve şebeke

Bu yedek sistemde, şebekeden gelen AC solar panellerden gelen enerjiye ilave yapabilir. Ve aynı şekilde, solar panellerden gelen enerji oluşabilecek tüm şebeke kesintilerini telafi edebilir.



### MultiPlus'a karşı Quattro

MultiPlus ve Quattro ürünleri hem AC hem de DC sistemlerinde önemli bir rol oynar. Her ikisi de bir kutu içerisinde güçlü akü şarj cihazları ve invertörleridir. Mevcut AC kaynaklarının miktarı Quattro ile Multi arasında seçim yaparken belirleyici faktördür. Asıl fark akıllı kurallara bağlı olarak bir Quattro'nun iki AC kaynağı ve bunların arasında bir anahtar alabilmesidir. Tümleşik bir aktar ma anahtarına sahiptir. MultiPlus yalnızca bir AC kaynağı alabilir.

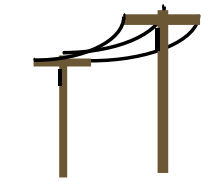

1'DE AC  
Şebeke

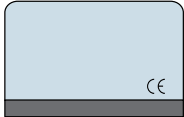

2'DE AC  
Jeneratör

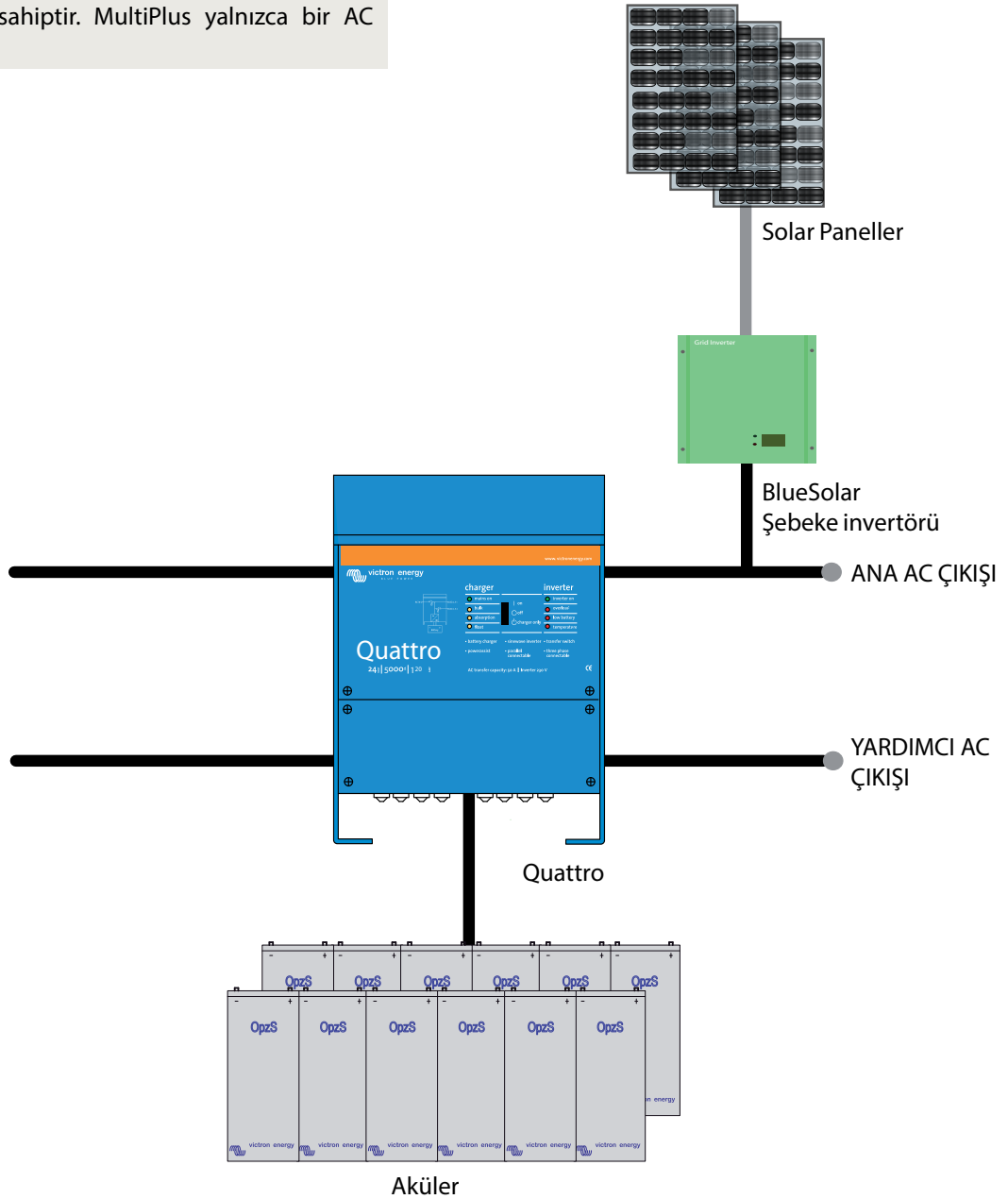

### 3. Solar, jeneratör ve şebeke

Burada gösterilen gibi kapsamlı bir yedek sistem kesintisiz bir enerji tedariki sağlar. Örneğin, bir şebeke kesintisi gerçekleşir, aküler boşalır ve aynı zamanda mevcut olarak kısıtlı miktarda solar enerji olursa, Quattro invertör/şarj cihazı jeneratörü çalıştırır. Jeneratöre artık ihtiyaç duyulmadığında, otomatik olarak durdurur.

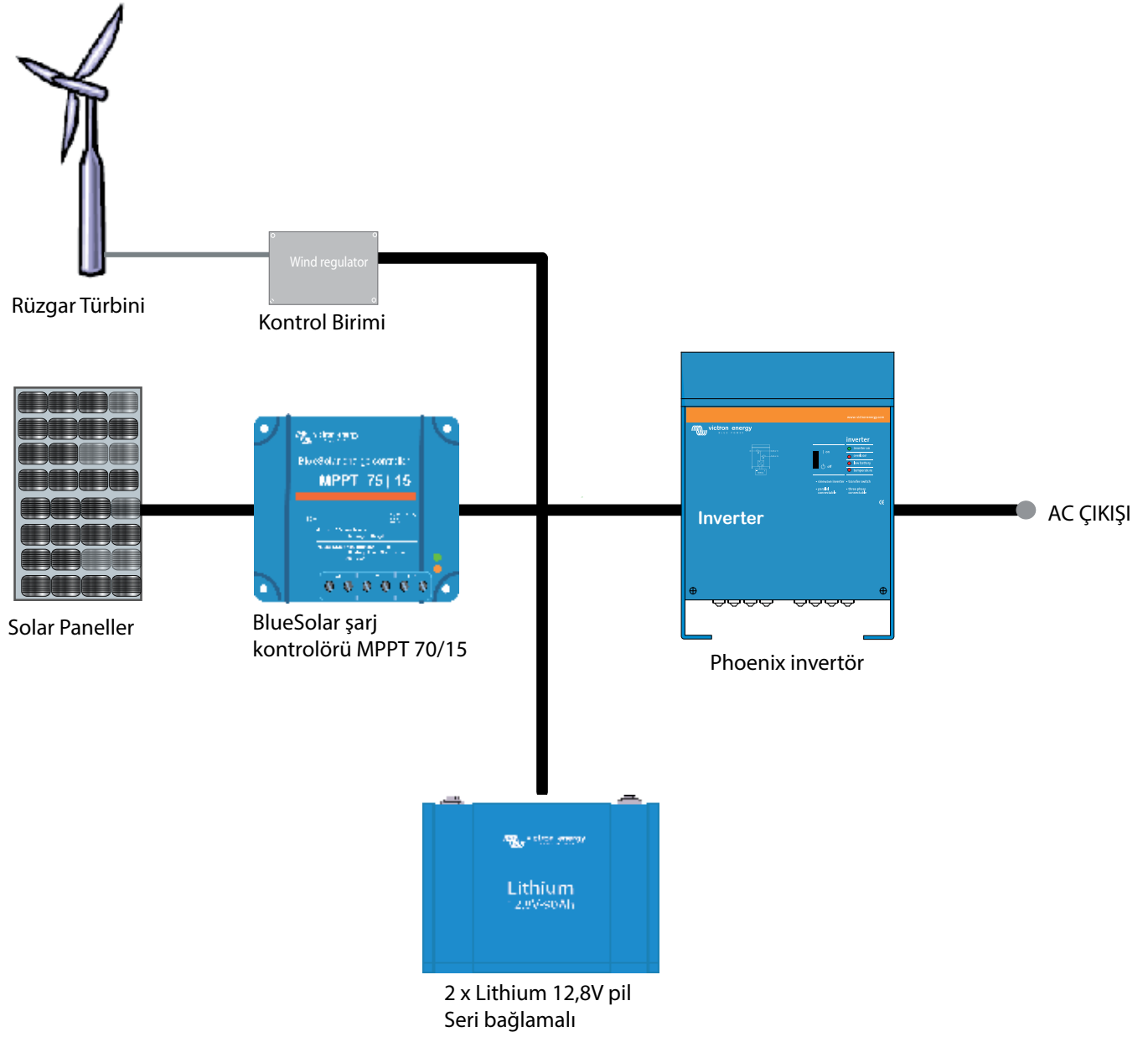

DC vasıtasıyla diğer yenilenebilir enerji kaynaklarının nasıl ekleneceğini gösteren örnek



Solar sistemlerimiz çeşitli bileşenlerden oluşur. Bunlardan bazıları solar sistemler için özel olarak tasarlanır. Diğer Victron bileşenlerimiz geniş bir takım uygulamalar için kullanılabilir. Bu bileşenler hakkındaki teknik özellikleri ve diğer detaylı bilgileri 'de "Teknik Bilgiler" bölümünde bulabilirsiniz.



#### Akü Monitörü

Victron Akü Monitörünün temel görevleri şarj ve deşarj akımlarının ölçülmesi, ayrıca şarj durumunu ve akünün kalan süresini hesaplamaktır. Belli limitler aşıldığında bir alarm gönderilir (örneğin aşırı deşarj). Akü monitörünün Victron Global Remote ile veri alışverişi yapması da mümkündür. Bu alarmların gönderilmesini de kapsar.



#### Color Control GX

Color Control GX, kendisine bağlı tüm ürünlere yönelik sezgisel bir kontrol ve izleme olanağı sunmaktadır. Color Control GX'e bağlanabilir Victron ürünlerinin listesi son derece geniştir: İnvertörler, Çoklu sistemler, Quattro'lar, MPPT 150/70, BMV-600 serileri, BMV-700 serileri, Skylla-i, Lynx Ion ve daha fazlası.



#### VRM Çevrim İçi Portal

Color Control GX'teki ürünlerin görüntülenmesi ve kontrol edilmesinin yanı sıra, bu bilgiler ayrıca ücretsiz uzaktan izleme web sitemiz VRM Çevrim İçi Portal'a da gönderilmektedir. VRM Çevrim İçi Portal hakkında bilgi edinmek için <https://vrm.victronenergy.com> adresini ziyaret edin ve sitedeki "Take a look inside" (Siteye göz at) butonuna basın. Bu portal ücretsizdir.



#### Dijital Çoklu Kontrol Paneli

Bu panel ile, Multiplus ve Quattro sistemlerini uzaktan izleyebilir ve kontrol edebilirsiniz. Düğmenin basit bir hareketle döndürülmesi örneğin bir jeneratörün ve/veya kıyı tarafı akımının güç kaynağını sınırlayabilir. Ayar aralığı en fazla 200A'dır.

Bu broşürde gösterilen AC ve DC sistemleri Victron Energy'nin sunduğu çeşitli imkanların örnekleridir. Gösterildiği üzere, basitten çok kapsamlı çözümlere kadar farklılaşabilirler. Gerekli güç tek bir ünite için çok yüksekse ürünlerimiz paralel veya üç-fazlı konfigürasyonlar şeklinde kullanılabilir.

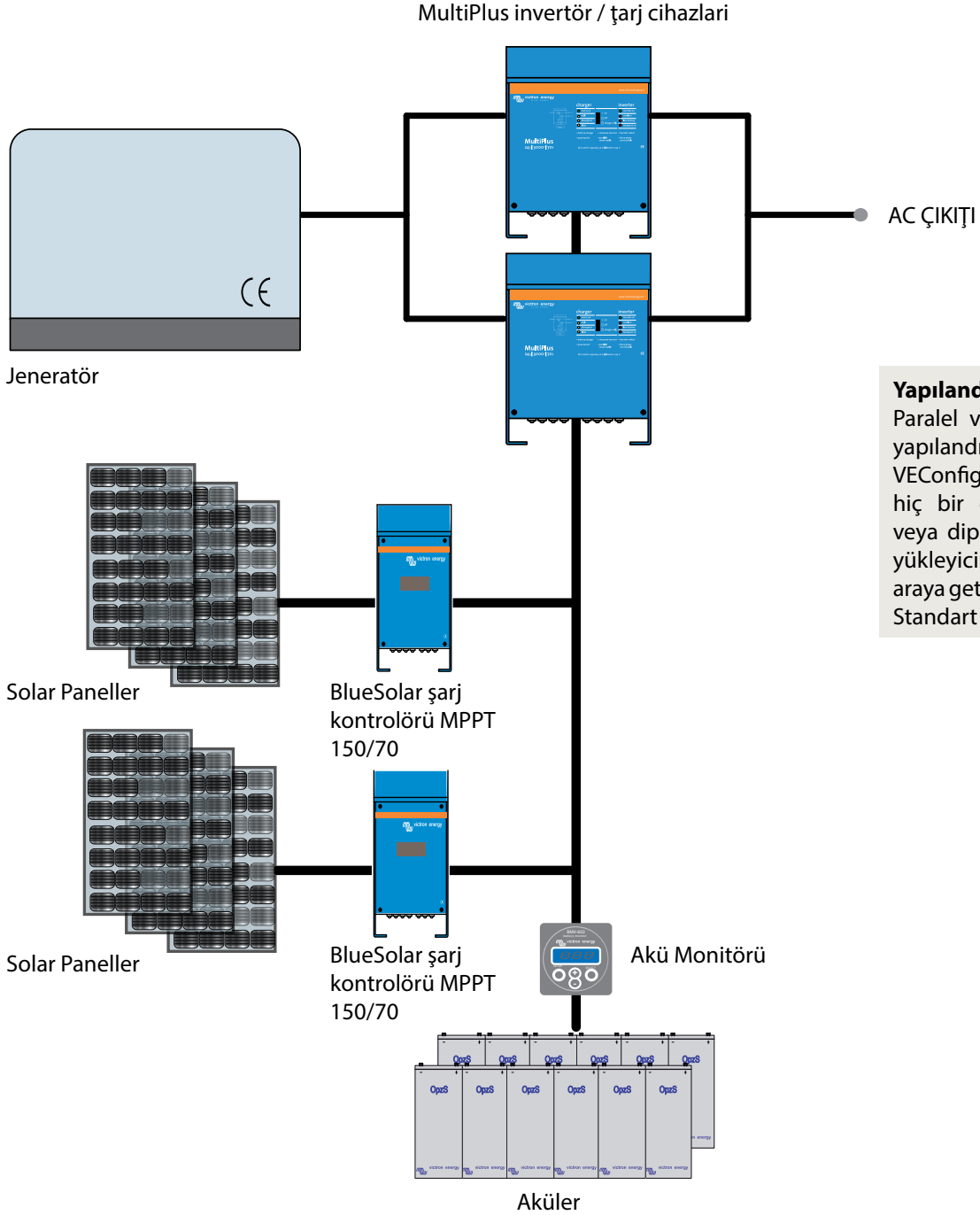

**Yapılandırılması kolay**

Paralel ve üç fazlı sistemleri yapılandırmak kolaydır. VEConfigure yazılım aracımız hiç bir donanım değişikliği veya dip anahtarı olmaksızın yükleyicinin bileşenleri bir araya getirmesine imkan tanır. Standart ürünleri kullanır.

**1. DC sistemi**

Yukarıdaki resim paralel tek bir jeneratör olarak yapılandırılan üç şarj kontrol birimi, iki MultiPlus invertör/şarj aletini göstermektedir.



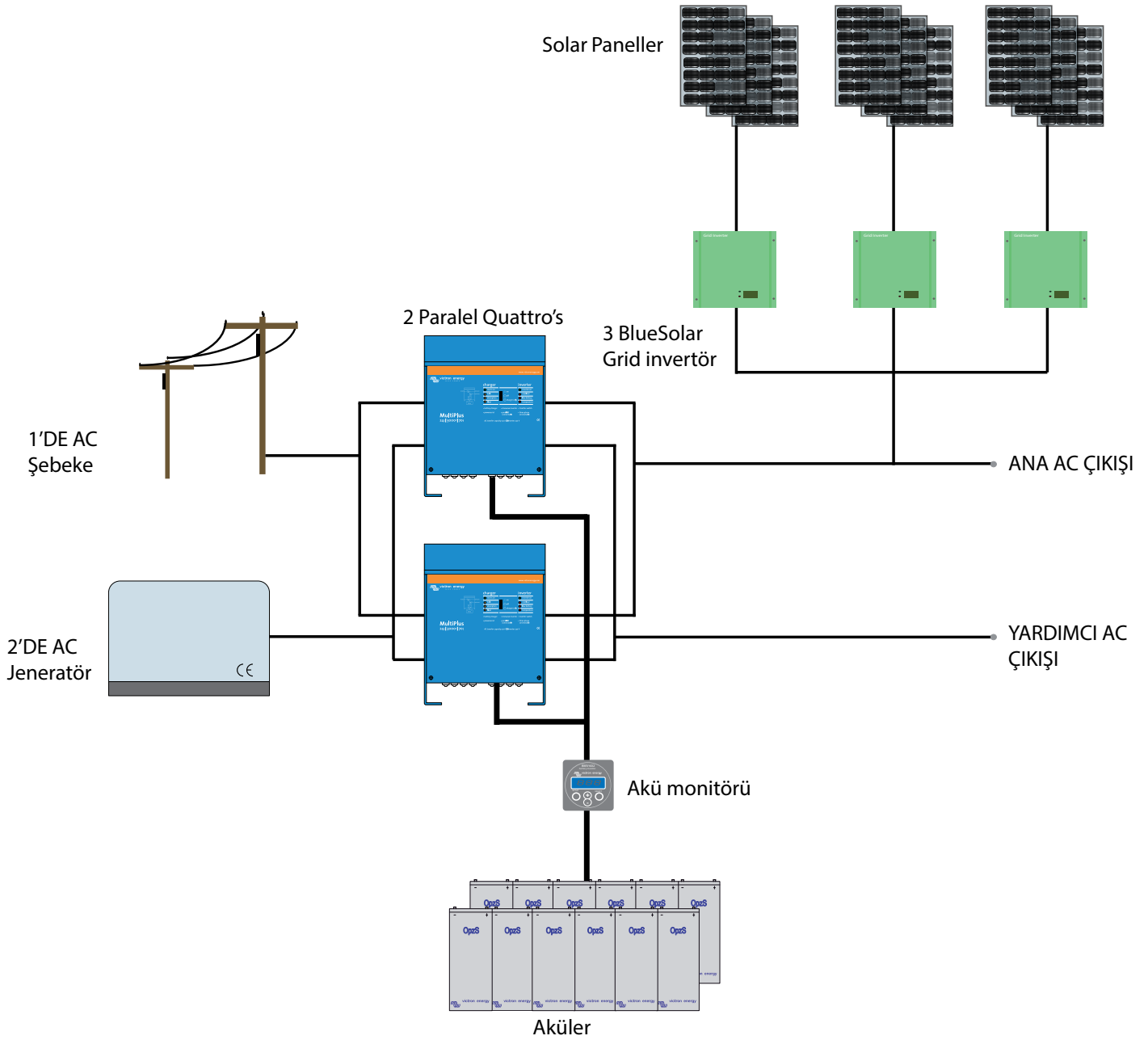

## 2. AC sistemi

Yukarıdaki resim paralel olarak üç şebeke invertörüne ve iki Quattro'ya sahip bir AC sistemini göstermektedir.





Not: En yeni veri sayfalarımız için lütfen websitemize bakınız:  
[www.victronenergy.com](http://www.victronenergy.com)

## TEKNİK BİLGİLER

EasySolar 12V and 24V: the all-in-one solar power solution	26
EasySolar 24V and 48V, 3000VA	28
ECMulti	31
Phoenix inverters 180VA - 1200VA 120V and 230V	34
Phoenix inverters 180VA - 1200VA - 5000VA 230V	36
MultiPlus inverter/charger 800VA- 5kVA 230V	38
Quattro inverter/charger 3kVA - 10kVA 230V	40
MultiPlus inverter/charger 2kVA and 3kVA 120V	42
Quattro inverter/charger 3kVA - 5kVA 120V	44
Blue Power IP65 Charger	47
Skylla-i battery charger 24V	50
Skylla charger 24/48V	52
Skylla TG charger 24V 90-265V GL approved	54
Color Control GX	56
BMV 700 series: Precision battery monitoring	60
BlueSolar monocrystalline panels	64
BlueSolar polycrystalline panels	65
BlueSolar charge controller MPPT 75/10, 75/15 & MPPT 100/15	66
BlueSolar charge controller MPPT 100/30	67
BlueSolar charge controller MPPT 100/50	68
BlueSolar charge controller MPPT 150/35	69
BlueSolar charge controller MPPT 150/45, MPPT 150/60 & MPPT 150/70	70
BlueSolar charge controller MPPT 150/70 & MPPT 150/85	71
BlueSolar PWM-Light charge controllers	72
BlueSolar PWM-Pro charge controllers	73
Battery Balancer	76
Telecom batteries	78
OPzS Solar batteries	79
Gel and AGM batteries	80
12,8 Volt lithium iron phosphate batteries	84
VE.Bus BMS	86
24V 180Ah Lithium-ion battery and Lynx-ion	88

## EasySolar 12V and 24V: the all-in-one solar power solution



### All-in-one solar power solution

The EasySolar combines a MPPT solar charge controller, an inverter/charger and AC distribution in one enclosure.

The product is easy to install, with a minimum of wiring.

### The solar charge controller: Blue Solar MPPT 100/50

Up to three strings of PV panels can be connected to three sets of MC<sub>4</sub> (PV-ST01) PV connectors.

### The inverter/charger: MultiPlus Compact 12/1600/70 or 24/1600/40

The MPPT charge controller and the MultiPlus Compact inverter/charger share the DC battery cables (included). The batteries can be charged with solar power (BlueSolar MPPT) and/or with AC power (inverter/charger) from the utility grid or a genset.

### AC distribution

The AC distribution consists of a RCD (30 mA/16 A) and four AC outputs protected by two 10 A and two 16 A circuit breakers.

One 16 A output is controlled by the AC input: it will switch on only when AC is available.

### PowerAssist

Unique PowerAssist technology protects the utility or generator supply from being overloaded by adding extra inverter power when needed.

### Unique solar application software

Several software programs (Assistants) are available to configure the system for various grid interactive or stand-alone applications. Please see

<http://www.victronenergy.nl/support-and-downloads/software/>

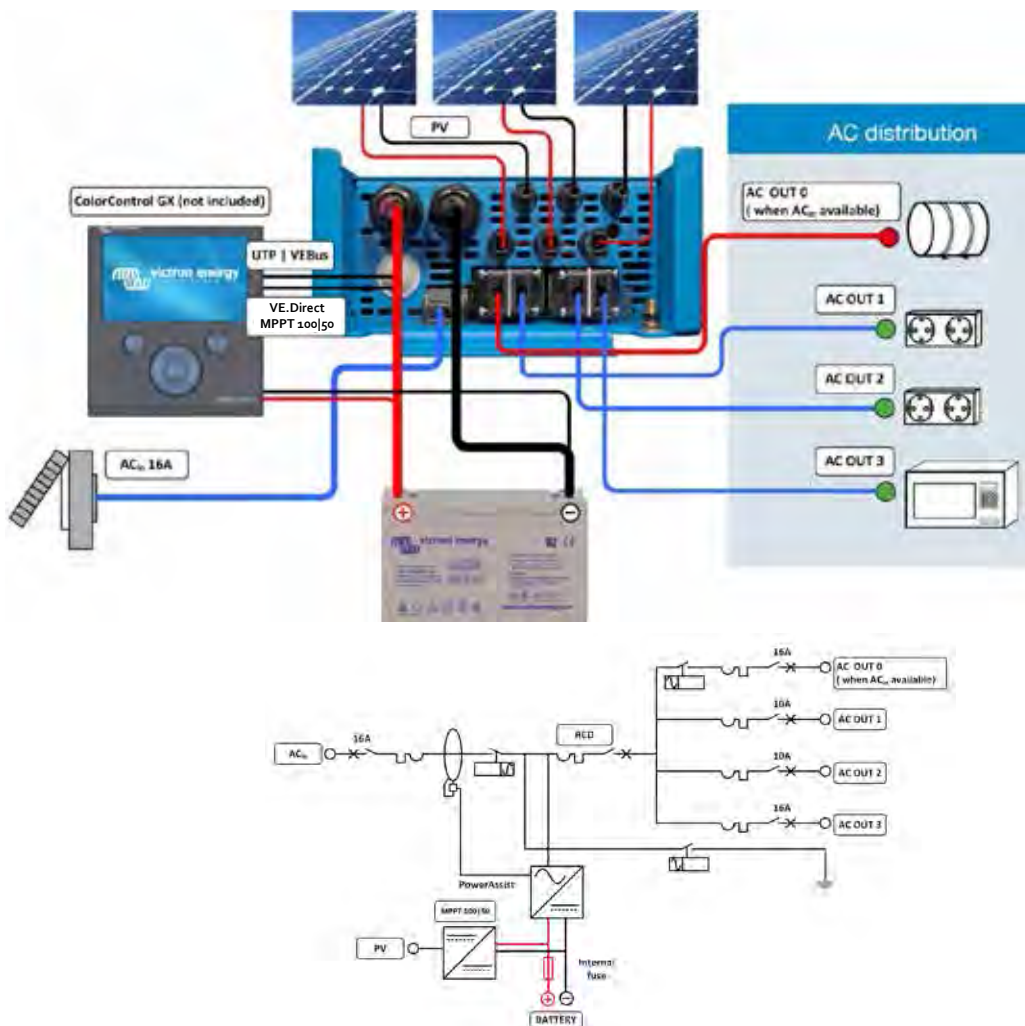

EasySolar	EasySolar 12/1600/70	EasySolar 24/1600/40
<b>Inverter/charger</b>		
Transfer switch	16 A	
<b>INVERTER</b>		
Input voltage range	9,5 – 17 V	19 – 33 V
'Heavy duty' output AC o	16 A	
Output AC <sub>1, 2, 3</sub>	Output voltage: 230 VAC ± 2% Frequency: 50 Hz ± 0,1% (1)	
Cont. output power at 25°C (3)	1600 VA / 1300 W	
Cont. output power at 40°C	1200 W	
Peak power	3000 W	
Maximum efficiency	92%	94%
Zero-load power	8 W	10 W
Zero load power in search mode	2 W	3 W
<b>CHARGER</b>		
AC Input	Input voltage range: 187-265 VAC Input frequency: 45 – 65 Hz    Power factor: 1	
Charge voltage 'absorption'	14,4 V	28,8 V
Charge voltage 'float'	13,8 V	27,6 V
Storage mode	13,2 V	26,4 V
Charge current house battery (4)	70 A	40 A
Charge current starter battery (A)	4	
Battery temperature sensor	yes	
Programmable relay (5)	yes	
Protection (2)	a - g	
<b>Solar Charge Controller</b>		
Model	MPPT 100/50	
Maximum output current	50 A	
Maximum PV power, 6a,b)	700 W	1400 W
Maximum PV open circuit voltage	100 V	100 V
Maximum efficiency	98%	
Self-consumption	10 mA	
Charge voltage 'absorption', default setting	14,4 V	28,8 V
Charge voltage 'float', default setting	13,8 V	27,6 V
Charge algorithm	multi-stage adaptive	
Temperature compensation	-16 mV / °C	-32 mV / °C
Protection	a - g	
<b>COMMON CHARACTERISTICS</b>		
Operating temp. range	-20 to +50°C (fan assisted cooling)	
Humidity (non-condensing):	max 95%	
<b>ENCLOSURE</b>		
Material & Colour	aluminium (blue RAL 5012)	
Protection category	IP 21	
Battery-connection	Battery cables of 1.5 meter	
PV connection	Three sets of MC <sub>4</sub> (PV-ST01) PV connectors.	
230 V AC-connection	G-ST18i connector	
Weight	15 kg	
Dimensions (hwxwd)	745 x 214 x 110 mm	
<b>STANDARDS</b>		
Safety	EN 60335-1, EN 60335-2-29, EN 62109	
Emission / Immunity	EN 55014-1, EN 55014-2, EN 61000-3-3	
Automotive Directive	2004/104/EC	
1) Can be adjusted to 60 Hz and to 240 V 2) Protection a. Output short circuit b. Overload c. Battery voltage too high d. Battery voltage too low e. Temperature too high f. 230 VAC on inverter output g. Input voltage ripple too high	3) Non-linear load, crest factor 3:1 4) At 25°C ambient 5) Programmable relay which can be set for general alarm, DC under voltage or genset start signal function 6a) If more PV power is connected, the controller will limit input power to 700 W resp. 1400 W 6b) PV voltage must exceed Vbat + 5 V for the controller to start. Thereafter minimum PV voltage is Vbat + 1 V	



### All-in-one solar power solution

The EasySolar combines two MPPT solar charge controller and an inverter/charger in one enclosure.

The product is easy to install, with a minimum of wiring.

### Two solar charge controllers: 2x Blue Solar MPPT 100/50, or 2x Blue Solar MPPT 150/35

Up to six strings of PV panels can be connected to six sets of MC4 (PV-ST01) PV connectors.

### The inverter/charger: MultiPlus Compact 24/3000/70-50 or 48/3000/35-50

The MPPT charge controllers and the MultiPlus inverter/charger share the DC battery connection. The batteries can be charged with solar power (2x BlueSolar MPPT) and/or with AC power (inverter/charger) from the utility grid or a genset.

### PowerAssist

Unique PowerAssist technology protects the utility or generator supply from being overloaded by adding extra inverter power when needed.

### Unique solar application software

Several software programs (Assistants) are available to configure the system for various grid interactive or stand-alone applications. Please see <http://www.victronenergy.nl/support-and-downloads/software/>

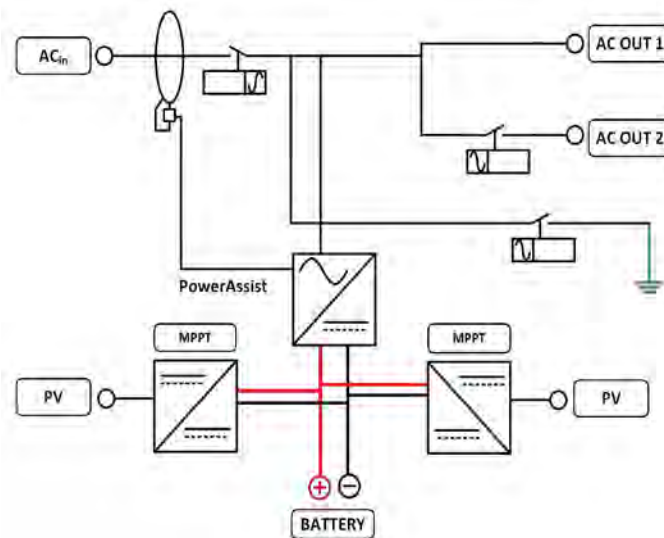
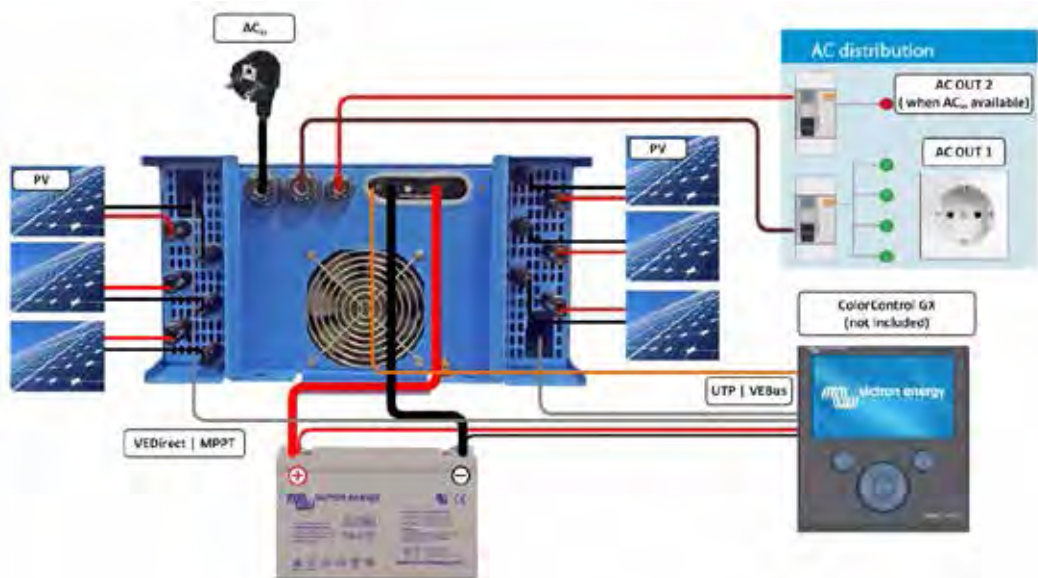

EasySolar	EasySolar 24/3000/70-50	EasySolar 48/3000/35-50
<b>Inverter/charger</b>		
Transfer switch	50 A	
<b>INVERTER</b>		
Input voltage range	19 - 33 V	38 – 63 V
Output	Output voltage: 230 VAC ± 2% Frequency: 50 Hz ± 0,1% (1)	
Cont. output power at 25°C (3)	3000 VA / 2500 W	
Cont. output power at 40°C	2200 W	
Peak power	6000 W	
Maximum efficiency	94%	95%
Zero load power	15 W	16 W
Zero load power in search mode	5 W	5 W
<b>CHARGER</b>		
AC Input	Input voltage range: 187-265 VAC Input frequency: 45 – 65 Hz Power factor: 1	
Charge voltage 'absorption'	28,8 V	57,6 V
Charge voltage 'float'	27,6 V	55,2 V
Storage mode	26,4 V	52,8 V
Charge current house battery (4)	70 A	35 A
Charge current starter battery (A)	4	
Battery temperature sensor	yes	
Programmable relay (5)	yes	
Protection (2)	a - g	
<b>Solar Charge Controller</b>		
Model	2x MPPT 100/50	2x MPPT 150/35
Maximum output current	2x 50 A	2x 35 A
Maximum PV power, 6a,b)	2x 1400 W	2x 2000 W
Maximum PV open circuit voltage	100 V	150 V
Maximum efficiency	98%	
Self-consumption	10 mA	
Charge voltage 'absorption', default setting	28,8 V	57,6 V
Charge voltage 'float', default setting	27,6 V	55,2 V
Charge algorithm	multi-stage adaptive	
Temperature compensation	-16 mV / °C	-32 mV / °C
Protection	a - g	
<b>COMMON CHARACTERISTICS</b>		
Operating temp. range	-20 to +50°C (fan assisted cooling)	
Humidity (non-condensing):	max 95%	
<b>ENCLOSURE</b>		
Material & Colour	aluminium (blue RAL 5012)	
Protection category	IP 21	
Battery-connection	Four M8 bolts (2 plus and 2 minus connections)	
230 V AC-connection	Screw terminals 13 mm <sup>2</sup> (6 AWG)	
PV connection	Six sets of MC4 (PV-ST01) PV connectors.	
Weight	21 kg	
Dimensions (hwxwd)	362 x 374 x 218 mm	
<b>STANDARDS</b>		
Safety	EN 60335-1, EN 60335-2-29, EN 62109, IEC 62109	
Emission / Immunity	EN 55014-1, EN 55014-2, EN 61000-3-3	
1) Can be adjusted to 60Hz and to 240V 2) Protection a. Output short circuit b. Overload c. Battery voltage too high d. Battery voltage too low e. Temperature too high f. 230VAC on inverter output g. Input voltage ripple too high	3) Non-linear load, crest factor 3:1 4) At 25°C ambient 5) Programmable relay which can a.o. be set for general alarm, DC under voltage or genset start signal function 6a) If more PV power is connected, the solar charge controllers will limit input power to 1400 W resp. 2000 W 6b) PV voltage must exceed Vbat + 5 V for the controller to start. Thereafter minimum PV voltage is Vbat + 1 V	

BIDIRECTIONAL CONVERTER	
GridAssist function	In case of overload the ECOMulti will import power from the grid to prevent system shutdown.
Maximum AC current feed-through	50 A
AC voltage	230 V 50 Hz single phase
Cont. output power at 25 °C	3000 VA
Cont. output power at 25 °C	2500 W
Cont. output power at 40 °C	2200 W
Peak power	6000 W
Maximum efficiency	94%
Power factor range (when connected to the grid)	0,7 inductive to 0,7 capacitive (programmable)
Zero-load power (W)	15 W
Zero load power in AES mode	10 W (island mode operation with AC output lowered to 200 V when load < 50 Watt)
Charge voltage 'absorption'	28,2 V
Charge voltage 'float'	26,7 V
Maximum charge current	70 A
Maximum battery depth of discharge (DoD)	80%
Auxiliary output	To connect additional loads once the battery has been fully charged: 16 A relay
Programmable relay	For monitoring, alarm or other purposes
VE.Bus communication port	For parallel and three phase operation, remote monitoring, remote control and system integration
General purpose communication port	Yes
Remote on-off	Yes
BATTERY	
Technology	Lithium Iron Phosphate
Nominal voltage	25,6 V
Nominal energy at 25°C	2,3 kWh
Nominal capacity at 25°C	90 Ah
Nominal capacity at 0°C	72 Ah
Nominal capacity at -20°C	45 Ah
Battery Management System	Cell balancing, and system shutdown in case of cell over voltage, cell under voltage and over temperature
Cycle life, 80% DoD	2000 cycles
Cycle life, 70% DoD	3000 cycles
Cycle life, 50% DoD	5000 cycles
Max storage time at 25 °C	1 year
OTHER	
Display	Graphical display Graphical User Interface (GUI) Ethernet (standard) and Wifi (optional) for remote monitoring and control Data storage and graphical display on vrm.victronenergy.com Android and iPhone apps
Operating temperature	-20 to + 40°C
Storage temperature	-40 to + 50°C
Protection category	IP22
Humidity	95% non condensing
Warranty	System: 5 years Battery: 3 years full warranty plus 7 years prorated warranty
ENCLOSURE	
Colour	Blue RAL 5012
Weight	Without battery: 28 kg With battery: 60 kg
Dimensions (hxwxwd)	475 x 575 x 360 mm
STANDARDS	
Safety	EN 60335-1, EN 60335-2-29, VDE-AR-N 4105
Emission, Immunity	EN55014-1, EN 55014-2, EN 61000-3-3







# ECOmulti

A simple wall mounted energy storage solution



## Nighttime

During the night the **ECOmulti** is disconnected from the grid. The home is powered by energy stored in the battery. The **ECOmulti** will reconnect the grid when the battery is discharged.



## Battery charging

The next day, when the PV array produces sufficient power to supply the loads and to start charging the battery, the **ECOmulti** will regulate charge current to absorb nearly 100% of the surplus PV power.



## Discharging during the day

When PV output is reduced by clouds or when a power hungry load is switched on, resulting in no surplus PV power available, battery charging will stop. Insufficient PV power will be supplemented by power from the **ECOmulti**. In case of overload power will be imported from the grid to supplement power from the **ECOmulti** (GridAssist function), and system shut down due to overload will be prevented.



## Battery fully charged

Once the battery is fully charged, additional loads (for example the water heater) can be switched on, or surplus power will be exported to the grid.

## End of the day

The **ECOmulti** disconnects from the grid about 10 minutes after PV power has become insufficient to provide any charge current. In order to prevent false disconnections due to lack of sun during the day, the inverter/charger also uses an internal timer to predict the end of the day.

## UPS function

When the grid fails, the **ECOmulti** will continue to power the home.

### Sizing the PV array

Sufficient energy must be harvested to recharge the battery and to power the home, even on a reasonably clear winter day.

At roughly 50 degrees latitude (Seattle, London, Amsterdam, Berlin, München) the two person energy conscious household will need a 2,5 kWp array. A four person household would need a 5 kWp array.

At roughly 30 to 40 degrees latitude (Los Angeles, Marseille, Sevilla) a 1 kWp resp. 2 kWp array will do.

A larger PV array will increase feedback into the grid, but not substantially increase battery utilization and self sufficiency.

### Increasing storage capacity

More battery storage capacity will reduce feedback into the grid and increase self sufficiency, especially during the summer season.

To increase self sufficiency during wintertime both the battery and the PV array have to be enlarged.

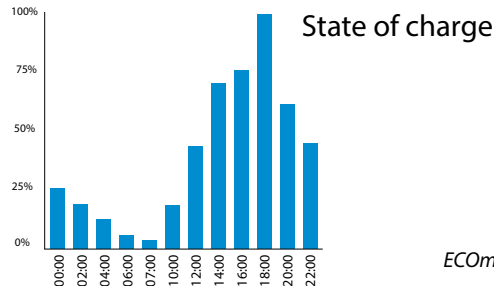
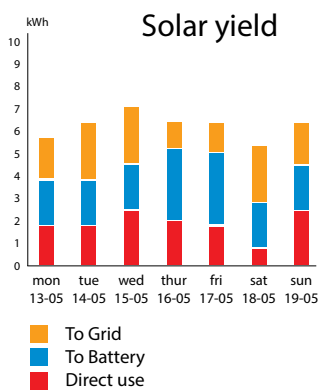

ECOMulti app

### Why 2,3 kWh?

Whenever PV output exceeds consumption, storing excess output for later use will increase self-consumption.

### However

- PV harvest will fluctuate from season to season, from day to day and also within the day.
- Electricity consumption is likewise fluctuating: working days, weekends and holiday periods will all result in different consumption patterns.

A 2,3 kWh Li-ion battery is an efficient solution for a two person energy conscious household. Energy consumption from dusk to dawn will be 2 kWh or more, even when no energy hungry appliances like a dishwasher or clothes dryer are used. A fully charged 2,3 kWh battery will therefore be discharged before the sun starts shining again.

The average household with two children would fully utilize a 4,6 kWh Li-ion battery; one additional battery module.

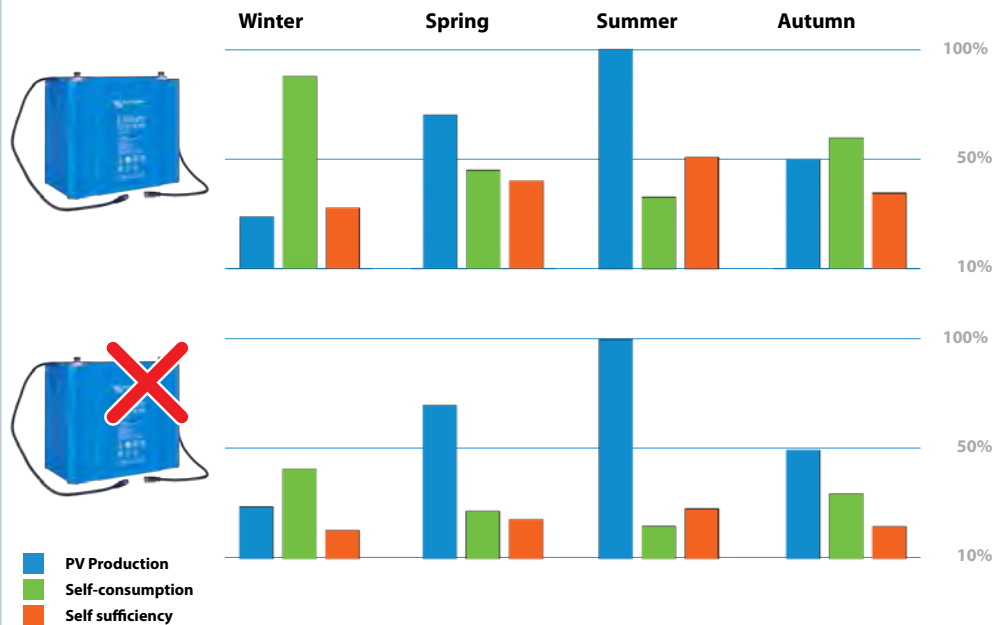

Typical seasonal variations at roughly 50 degrees latitude ~ Seattle, London, Amsterdam, Berlin, München ~ with battery and without battery.

### Two person energy conscious household

Consumption: 2500 kWh per year  
 PV array: 2,5 kWp  
 Battery: 2,3 kWh Li-ion

### Four person energy conscious household

Consumption: 4500 kWh per year  
 PV array: 5 kWp  
 Battery: 4,6 kWh Li-ion

### A simple wall mounted energy storage solution

The **ECOMulti** can be wall mounted, is easy to install, easy to program and easy to operate.

### Extremely flexible

- Energy storage can be increased by adding battery modules.
- AC power can be increased by paralleling **ECOMulti** modules.
- Three **ECOMulti** modules can be configured for three phase operation.
- Two **ECOMulti** modules can be configured for split phase operation.

### More self-consumption, more independence

With 2,3 kWh Li-ion storage capacity and a 3 kVA bidirectional inverter, the **ECOMulti** reduces dependence on power from the grid.

The growing interest in self-consumption is driven by increasing retail electricity prices and simultaneously decreasing feed in tariffs. Feed in tariffs are decreasing a. o. because it becomes increasingly difficult, and expensive, to ensure stability of the grid as more solar and wind power comes on line. Simultaneously, the retail price of electricity is increasing, to cover these same costs plus the cost to keep conventional power plants in hot standby to back-up renewable power generation in case the sun is not shining and/or the wind is not blowing.

The **ECOMulti** meets the German interconnection standard *VDE-AR-N 4105* and the Incentive Program for Solar Energy Storage Systems *Marktanzreizprogramm für Batteriespeicher*.

With Intelligent Battery and Load Management the **ECOMulti** can limit power export to the grid to at most 60% of the installed Wp capacity; *KfW-Programm Erneuerbare Energien "Speicher"*.

According to the Fraunhofer-Institut für Solare Energiesysteme (ISE), a household that consumes 4500 kWh per year can reduce energy import from the grid by 60% when installing a 5 kWp solar array combined with 4 kWh usable energy storage.

For more information please download our white paper *Self-consumption or grid independence* from [www.victronenergy.com](http://www.victronenergy.com).

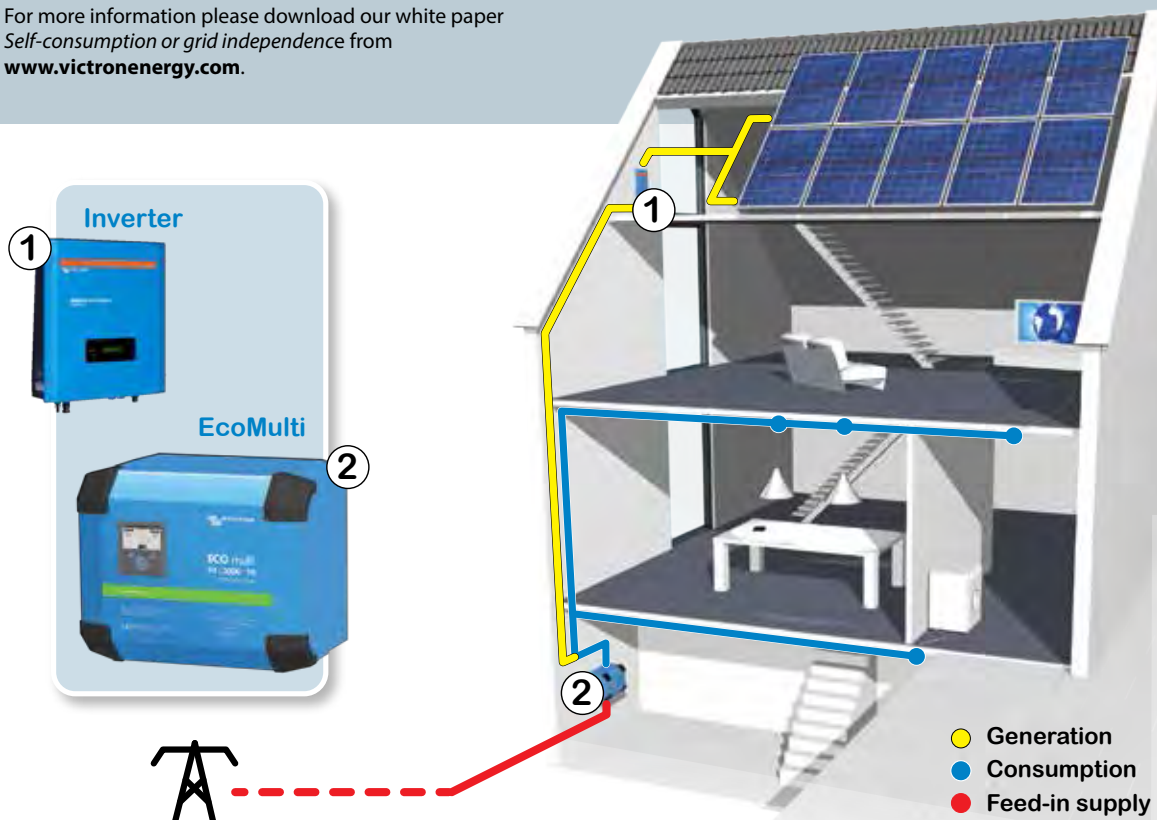





Phoenix Inverter  
12/180

### SinusMax – Superior engineering

Developed for professional duty, the Phoenix range of inverters is suitable for the widest range of applications. The design criteria have been to produce a true sine wave inverter with optimized efficiency but without compromise in performance. Employing hybrid HF technology, the result is a top quality product with compact dimensions, light in weight and capable of supplying power, problem-free, to any load.

### Extra start-up power

A unique feature of the SinusMax technology is very high start-up power. Conventional high frequency technology does not offer such extreme performance. Phoenix Inverters, however, are well suited to power up difficult loads such as computers and low power electric tools.

### To transfer the load to another AC source: the automatic transfer switch

For our lower power models we recommend the use of our Filax Automatic Transfer Switch. The Filax features a very short switchover time (less than 20 milliseconds) so that computers and other electronic equipment will continue to operate without disruption.



Phoenix Inverter  
12/800 with Schuko socket

### LED diagnosis

Please see manual for a description.

### Remote on/off switch

Connector for remote on/off switch available on all models.

### DIP switch for 50/60Hz selection (48/350 model only)

### Available with different output sockets

Please see pictures below.



Phoenix Inverter 12/350  
with IEC-320 sockets



Phoenix Inverter 12/180  
with Schuko socket



Phoenix Inverter 12/180  
with Nema 5-15R sockets



Phoenix Inverter 12/800  
with IEC-320 socket



Phoenix Inverter 12/800  
with Schuko socket



Phoenix Inverter 12/800  
with BS 1363 socket



Phoenix Inverter 12/800  
with AN/NZS 3112 socket



Phoenix Inverter 12/800  
with Nema 5-15R socket

Phoenix Inverter	12 Volt 24 Volt 48 Volt	12/180 24/180	12/350 24/350 48/350	12/800 24/800 48/800	12/1200 24/1200 48/1200
Cont. AC power at 25°C (VA) (3)		180	350	800	1200
Cont. power at 25°C / 40°C (W)		175 / 150	300 / 250	700 / 650	1000 / 900
Peak power (W)		350	700	1600	2400
Output AC voltage / frequency (4)		110 VAC or 230 VAC +/- 3% 50 Hz or 60 Hz +/- 0,1%			
Input voltage range (V DC)		10,5 - 15,5 / 21,0 - 31,0 / 42,0 - 62,0		9,2 - 17,3 / 18,4 - 34,0 / 36,8 - 68,0	
Low battery alarm (V DC)		11,0 / 22 / 44		10,9 / 21,8 / 43,6	
Low battery shut down (V DC)		10,5 / 21 / 42		9,2 / 18,4 / 36,8	
Low battery auto recovery (V DC)		12,5 / 25 / 50		12,5 / 25 / 50	
Max. efficiency (%)		87 / 88	89 / 89 / 90	91 / 93 / 94	92 / 94 / 94
Zero load power (W)		2,6 / 3,8	3,1 / 5,0 / 6,0	6 / 5 / 4	6 / 5 / 6
Zero load power in search mode		n. a.	n. a.	2	2
Protection (2)		a - e			
Operating temperature range		-40 to +50°C (fan assisted cooling)			
Humidity (non-condensing)		max 95%			
<b>ENCLOSURE</b>					
Material & Colour		aluminium (blue Ral 5012)			
Battery-connection		1)	1)	1)	1)
Standard AC outlets		230V: IEC-320 (IEC-320 plug included), CEE 7/4 (Schuko) 120V: Nema 5-15R			
Other outlets (at request)		BS 1363 (United Kingdom) AN/NZS 3112 (Australia, New Zealand)			
Protection category		IP 20			
Weight (kg / lbs)		2,7 / 5,4	3,5 / 7,7	6,5 / 14,3	8,5 / 18,7
Dimensions (hwxwx in mm) (hwxwx in inches)		72x132x200 2.8x5.2x7.9	72x155x237 2.8x6.1x9.3	104 x 194 x 305 4.1 x 7.6 x 12.0	104 x 194 x 305 4.1 x 7.6 x 12.0
<b>ACCESSORIES</b>					
Remote on-off switch		Two pole connector			
Automatic transfer switch		Filax			
<b>STANDARDS</b>					
Safety		EN 60335-1			
Emission Immunity		EN 55014-1 / EN 55014-2 / EN 61000-6-2 / EN 61000-6-3			
1) Battery cables of 1.5 meter (12/180 with cigarette plug) 2) Protection key: a) output short circuit b) overload c) battery voltage too high d) battery voltage too low e) temperature too high		3) Non-linear load, crest factor 3:1 4) Frequency can be set by DIP switch (48/350 model only)			



#### Battery Alarm

An excessively high or low battery voltage is indicated by an audible and visual alarm, and a relay for remote signalling.



#### BMV Battery Monitor

The BMV Battery Monitor features an advanced microprocessor control system combined with high resolution measuring systems for battery voltage and charge/discharge current. Besides this, the software includes complex calculation algorithms to exactly determine the state of charge of the battery. The BMV selectively displays battery voltage, current, consumed Ah or time to go. The monitor also stores a host of data regarding performance and use of the battery.



**Phoenix Inverter**  
24/5000

**SinusMax - Superior engineering**

Developed for professional duty, the Phoenix range of inverters is suitable for the widest range of applications. The design criteria have been to produce a true sine wave inverter with optimised efficiency but without compromise in performance. Employing hybrid HF technology, the result is a top quality product with compact dimensions, light in weight and capable of supplying power, problem-free, to any load.

**Extra start-up power**

A unique feature of the SinusMax technology is very high start-up power. Conventional high frequency technology does not offer such extreme performance. Phoenix inverters, however, are well suited to power up difficult loads such as refrigeration compressors, electric motors and similar appliances.

**Virtually unlimited power thanks to parallel and 3-phase operation capability**

Up to 6 units inverters can operate in parallel to achieve higher power output. Six 24/5000 units, for example, will provide 24kW / 30kVA output power. Operation in 3-phase configuration is also possible.

**To transfer the load to another AC source: the automatic transfer switch**

If an automatic transfer switch is required we recommend using the MultiPlus inverter/charger instead. The switch is included in these products and the charger function of the MultiPlus can be disabled. Computers and other electronic equipment will continue to operate without disruption because the MultiPlus features a very short switchover time (less than 20 milliseconds).

**Computer interface**

All models have a RS-485 port. All you need to connect to your PC is our MK2 interface (see under accessories). This interface takes care of galvanic isolation between the inverter and the computer, and converts from RS-485 to RS-232. A RS-232 to USB conversion cable is also available. Together with our VEConfigure software, which can be downloaded free of charge from our website, all parameters of the inverters can be customised. This includes output voltage and frequency, over and under voltage settings and programming the relay. This relay can for example be used to signal several alarm conditions, or to start a generator. The inverters can also be connected to VENet, the new power control network of Victron Energy, or to other computerised monitoring and control systems.

**New applications of high power inverters**

The possibilities of paralleled high power inverters are truly amazing. For ideas, examples and battery capacity calculations please refer to our book "Energy Unlimited" (available free of charge from Victron Energy and downloadable from [www.victronenergy.com](http://www.victronenergy.com)).



**Phoenix Inverter Compact**  
24/1600

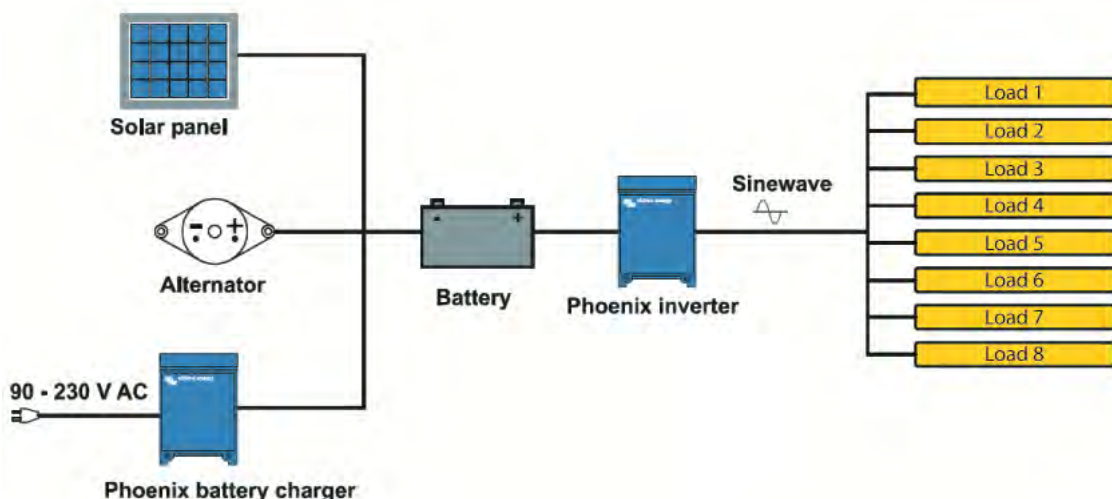



Phoenix Inverter	C12/1200 C24/1200	C12/1600 C24/1600	C12/2000 C24/2000	12/3000 24/3000 48/3000	24/5000 48/5000
Parallel and 3-phase operation	Yes				
<b>INVERTER</b>					
Input voltage range (V DC)	9,5 – 17V 19 – 33V 38 – 66V				
Output	Output voltage: 230 VAC ±2% Frequency: 50 Hz ± 0,1% (1)				
Cont. output power at 25 °C (VA) (2)	1200	1600	2000	3000	5000
Cont. output power at 25 °C (W)	1000	1300	1600	2500	4500
Cont. output power at 40 °C (W)	900	1200	1450	2200	4000
Peak power (W)	2400	3000	4000	6000	10000
Max. efficiency 12 / 24 / 48 V (%)	92 / 94	92 / 94	92 / 92	93 / 94 / 95	94 / 95
Zero-load power 12 / 24 / 48 V (W)	8 / 10	8 / 10	9 / 11	15 / 15 / 16	25 / 25
Zero-load power in AES mode (W)	5 / 8	5 / 8	7 / 9	10 / 10 / 12	20 / 20
Zero-load power in Search mode (W)	2 / 3	2 / 3	3 / 4	4 / 5 / 5	5 / 6
<b>GENERAL</b>					
Programmable relay (3)	Yes				
Protection (4)	a - g				
VE.Bus communication port	For parallel and three phase operation, remote monitoring and system integration				
Remote on-off	Yes				
Common Characteristics	Operating temperature range: -40 to +50 °C (fan assisted cooling) Humidity (non condensing): max 95%				
<b>ENCLOSURE</b>					
Common Characteristics	Material & Colour: aluminum (blue RAL 5012) Protection category: IP 21				
Battery-connection	battery cables of 1.5 meter included		M8 bolts	2+2 M8 bolts	
230 V AC-connection	G-ST18i plug		Spring-clamp	Screw terminals	
Weight (kg)	10		12	18	30
Dimensions (hxwxd in mm)	375x214x110		520x255x125	362x258x218	444x328x240
<b>STANDARDS</b>					
Safety	EN 60335-1				
Emission Immunity	EN 55014-1 / EN 55014-2				
1) Can be adjusted to 60Hz and to 240V 2) Non linear load, crest factor 3:1 3) Programmable relay that can a.o. be set for general alarm, DC undervoltage or genset start/stop function. AC rating: 230V/4A DC rating: 4a up to 35VDC, 1A up to 60VDC	4) Protection key: a) output short circuit b) overload c) battery voltage too high d) battery voltage too low e) temperature too high f) 230 V AC on inverter output g) input voltage ripple too high				



### Phoenix Inverter Control

This panel can also be used on a MultiPlus inverter/charger when an automatic transfer switch but no charger function is desired. The brightness of the LEDs is automatically reduced during night time.



### Computer controlled operation and monitoring

Several interfaces are available:

- **MK2.2 VE.Bus to RS232 converter**  
Connects to the RS232 port of a computer (see 'A guide to VEConfigure')
- **MK2-USB VE.Bus to USB converter**  
Connects to a USB port (see 'A guide to VEConfigure')
- **VE.Net to VE.Bus converter**  
Interface to VE.Net (see VE.Net documentation)
- **VE.Bus to NMEA 2000 converter**
- **Victron Global Remote**  
The Global Remote is a modem which sends alarms, warnings and system status reports to cellular phones via text messages (SMS). It can also log data from Victron Battery Monitors, Multi's, Quattro's and Inverters to a website through a GPRS connection. Access to this website is free of charge.
- **Victron Ethernet Remote**  
To connect to Ethernet.



### BMV Battery Monitor

The BMV Battery Monitor features an advanced microprocessor control system combined with high resolution measuring systems for battery voltage and charge / discharge current. Besides this, the software includes complex calculation algorithms, like Peukert's formula, to exactly determine the state of charge of the battery. The BMV selectively displays battery voltage, current, consumed Ah or time to go. The monitor also stores a host of data regarding performance and use of the battery.

Several models available (see battery monitor documentation).

**MultiPlus**  
**24/3000/70**

### Two AC Outputs

The main output has no break functionality. The MultiPlus takes over the supply to the connected loads in the event of a grid failure or when shore/generator power is disconnected. This happens so fast (less than 20 milliseconds) that computers and other electronic equipment will continue to operate without disruption. The second output is live only when AC is available on one of the inputs of the MultiPlus. Loads that should not discharge the battery, like a water heater for example can be connected to this output (second output available on models rated at 3 kVA and more).

### Virtually unlimited power thanks to parallel operation

Up to 6 Multis can operate in parallel to achieve higher power output. Six 24/5000/120 units, for example, will provide 25 kW / 30 kVA output power with 720 Amps charging capacity.

### Three phase capability

In addition to parallel connection, three units of the same model can be configured for three phase output. But that's not all: up to 6 sets of three units can be parallel connected for a huge 75 kW / 90 kVA inverter and more than 2000 Amps charging capacity.

### PowerControl - Dealing with limited generator, shore side or grid power

The MultiPlus is a very powerful battery charger. It will therefore draw a lot of current from the generator or shore side supply (nearly 10 A per 5 kVA Multi at 230 VAC). With the Multi Control Panel a maximum generator or shore current can be set. The MultiPlus will then take account of other AC loads and use whatever is extra for charging, thus preventing the generator or shore supply from being overloaded.

### PowerAssist - Boosting the capacity of shore or generator power

This feature takes the principle of PowerControl to a further dimension. It allows the MultiPlus to supplement the capacity of the alternative source. Where peak power is so often required only for a limited period, the MultiPlus will make sure that insufficient shore or generator power is immediately compensated for by power from the battery. When the load reduces, the spare power is used to recharge the battery.

### Solar energy: AC power available even during a grid failure

The Quattro can be used in off grid as well as grid connected PV and other alternative energy systems. Loss of mains detection software is available.

**MultiPlus Compact**  
**12/2000/80**

### System configuring

- In case of a stand-alone application, if settings have to be changed, this can be done in a matter of minutes with a DIP switch setting procedure.
- Parallel and three-phase applications can be configured with VE.Bus Quick Configure and VE.Bus System Configurator software.
- Off grid, grid interactive and self-consumption applications, involving grid-tie inverters and/or MPPT Solar Chargers can be configured with Assistants (dedicated software for specific applications).

### On-site Monitoring and control

Several options are available: Battery Monitor, Multi Control Panel, Ve.Net Blue Power Panel, Color Control Panel, smartphone or tablet (Bluetooth Smart), laptop or computer (USB or RS232).

### Remote Monitoring and control

Victron Ethernet Remote, Victron Global Remote and the Color Control Panel.

Data can be stored and displayed on our VRM (Victron Remote Management) website, free of charge.

### Remote configuring

When connected to the Ethernet, systems with a Color Control panel can be accessed and settings can be changed.

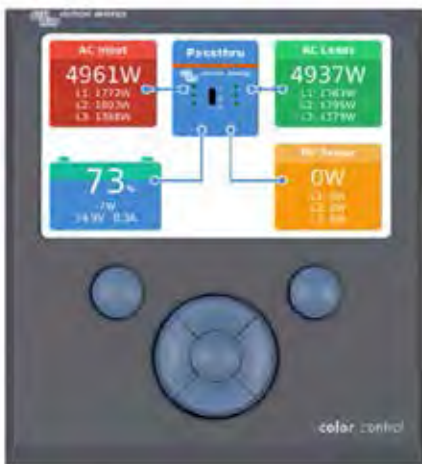
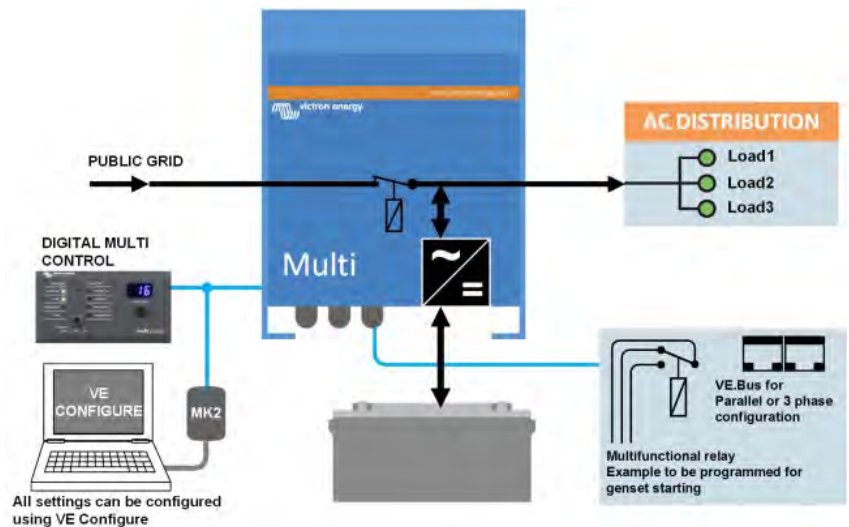
**Color Control Panel, showing a PV application**

MultiPlus	12 Volt 24 Volt 48 Volt	C 12/800/35 C 24/ 800/16	C 12/1200/50 C 24/1200/25	C 12/1600/70 C 24/1600/40	C 12/2000/80 C 24/2000/50	12/3000/120 24/3000/70 48/3000/35	24/5000/120 48/5000/70
PowerControl		Yes	Yes	Yes	Yes	Yes	Yes
PowerAssist		Yes	Yes	Yes	Yes	Yes	Yes
Transfer switch (A)		16	16	16	30	16 or 50	100
<b>INVERTER</b>							
Input voltage range (V DC)		9,5 – 17 V		19 – 33 V	38 – 66 V		
Output		Output voltage: 230 VAC ± 2%			Frequency: 50 Hz ± 0,1% (1)		
Cont. output power at 25°C (VA) (3)		800	1200	1600	2000	3000	5000
Cont. output power at 25°C (W)		700	1000	1300	1600	2500	4500
Cont. output power at 40°C (W)		650	900	1200	1450	2200	4000
Peak power (W)		1600	2400	3000	4000	6000	10.000
Maximum efficiency (%)		92 / 94	93 / 94	93 / 94	93 / 94	93 / 94 / 95	94 / 95
Zero load power (W)		8 / 10	8 / 10	8 / 10	9 / 11	15 / 15 / 16	25 / 25
Zero load power in AES mode (W)		5 / 8	5 / 8	5 / 8	7 / 9	10 / 10 / 12	20 / 20
Zero load power in Search mode (W)		2 / 3	2 / 3	2 / 3	3 / 4	4 / 5 / 5	5 / 6
<b>CHARGER</b>							
AC Input		Input voltage range: 187-265 VAC		Input frequency: 45 – 65 Hz	Power factor: 1		
Charge voltage 'absorption' (V DC)		14,4 / 28,8 / 57,6					
Charge voltage 'float' (V DC)		13,8 / 27,6 / 55,2					
Storage mode (V DC)		13,2 / 26,4 / 52,8					
Charge current house battery (A) (4)		35 / 16	50 / 25	70 / 40	80 / 50	120 / 70 / 35	120 / 70
Charge current starter battery (A)		4 (12 V and 24 V models only)					
Battery temperature sensor		yes					
<b>GENERAL</b>							
Auxiliary output (5)		n. a.	n. a.	n. a.	n. a.	Yes (16A)	Yes (25A)
Programmable relay (6)		Yes					
Protection (2)		a - g					
VE.Bus communication port		For parallel and three phase operation, remote monitoring and system integration					
General purpose com. port		n. a.	n. a.	n. a.	n. a.	Yes	Yes
Remote on-off		Yes					
Common Characteristics		Operating temp. range: -40 to +50°C (fan assisted cooling) Humidity (non-condensing): max 95%					
<b>ENCLOSURE</b>							
Common Characteristics		Material & Colour: aluminium (blue RAL 5012)			Protection category: IP 21		
Battery-connection		battery cables of 1.5 meter		M8 bolts	Four M8 bolts (2 plus and 2 minus connections)		
230 V AC-connection		G-ST181 connector		Spring-clamp	Screw terminals 13 mm <sup>2</sup> (6 AWG)		
Weight (kg)		10	10	10	12	18	30
Dimensions (hwxwd in mm)		375x214x110		520x255x125	362x258x218	444x328x240	
<b>STANDARDS</b>							
Safety		EN-IEC 60335-1, EN-IEC 60335-2-29, IEC 62109-1					
Emission, Immunity		EN 55014-1, EN 55014-2, EN 61000-3-3, EN 61000-6-3, EN 61000-6-2, EN 61000-6-1					
Automotive Directive		2004/104/EC					
Anti-islanding		See our website					
<p>1) Can be adjusted to 60 Hz, 120 V 60 Hz on request</p> <p>2) Protection key:  a) output short circuit  b) overload  c) battery voltage too high  d) battery voltage too low  e) temperature too high  f) 230 VAC on inverter output  g) input voltage ripple too high</p> <p>3) Non-linear load, crest factor 3:1  4) At 25°C ambient  5) Switches off when no external AC source available  6) Programmable relay that can a.o. be set for general alarm, DC under voltage or genset start/stop function  AC rating: 230 V/4A  DC rating: 4 A up to 35 VDC, 1 A up to 60 VDC</p>							



#### Digital Multi Control Panel

A convenient and low cost solution for remote monitoring, with a rotary knob to set PowerControl and PowerAssist levels.



#### Blue Power Panel

Connects to a Multi or Quattro and all VE.Net devices, in particular the VE.Net Battery Controller. Graphic display of currents and voltages.



#### Computer controlled operation and monitoring

Several interfaces are available:

- **MK2.2 VE.Bus to RS232 converter**  
Connects to the RS232 port of a computer (see 'A guide to VEConfigure')
- **MK2-USB VE.Bus to USB converter**  
Connects to a USB port (see 'A guide to VEConfigure')
- **VE.Net to VE.Bus converter**  
Interface to VE.Net (see VE.Net documentation)
- **VE.Bus to NMEA 2000 converter**
- **Victron Global Remote**

The Global Remote is a modem which sends alarms, warnings and system status reports to cellular phones via text messages (SMS). It can also log data from Victron Battery Monitors, Multis, Quattros and Inverters to a website through a GPRS connection. Access to this website is free of charge.

- **Victron Ethernet Remote**

To connect to the Ethernet.

- **Color Control panel (see picture on page 1)**

Behind the color LCD a Linux microcomputer runs open source software.

The Color Control (CCGX) provides intuitive control and monitoring for all products connected to it. The list of Victron products that can be connected is endless: Inverters, Multis, Quattros, all our latest MPPT Solar Chargers, BMV-700, BMV-600, Lynx Ion + Shunt and more. The information can also be forwarded to our free remote monitoring website: the VRM Online Portal.



#### BMV Battery Monitor

The BMV Battery Monitor features an advanced microprocessor control system combined with high resolution measuring systems for battery voltage and charge/discharge current. Besides this, the software includes complex calculation algorithms, like Peukert's formula, to exactly determine the state of charge of the battery. The BMV selectively displays battery voltage, current, consumed Ah or time to go. The monitor also stores a host of data regarding performance and use of the battery. Several models available (see battery monitor documentation).





Quattro  
48/5000/70-100/100



Quattro  
24/3000/70-50/50

**Two AC inputs with integrated transfer switch**

The Quattro can be connected to two independent AC sources, for example the public grid and a generator, or two generators. The Quattro will automatically connect to the active source.

**Two AC Outputs**

The main output has no-break functionality. The Quattro takes over the supply to the connected loads in the event of a grid failure or when shore/generator power is disconnected. This happens so fast (less than 20 milliseconds) that computers and other electronic equipment will continue to operate without disruption. The second output is live only when AC is available on one of the inputs of the Quattro. Loads that should not discharge the battery, like a water heater for example can be connected to this output.

**Virtually unlimited power thanks to parallel operation**

Up to 6 Quattro units can operate in parallel. Six units 48/10000/140, for example, will provide 54 kW / 60 kVA output power and 840 Amps charging capacity.

**Three phase capability**

Three units can be configured for three phase output. But that's not all: up to 6 sets of three units can be parallel connected to provide 162 kW / 180 kVA inverter power and more than 2500 A charging capacity.

**PowerControl – Dealing with limited generator, shoreside or grid power**

The Quattro is a very powerful battery charger. It will therefore draw a lot of current from the generator or shoreside supply (16 A per 5 kVA Quattro at 230 VAC). A current limit can be set on each AC input. The Quattro will then take account of other AC loads and use whatever is spare for charging, thus preventing the generator or mains supply from being overloaded.

**PowerAssist – Boosting shore or generator power**

This feature takes the principle of PowerControl to a further dimension allowing the Quattro to supplement the capacity of the alternative source. Where peak power is so often required only for a limited period, the Quattro will make sure that insufficient mains or generator power is immediately compensated for by power from the battery. When the load reduces, the spare power is used to recharge the battery.

**Solar energy: AC power available even during a grid failure**

The Quattro can be used in off grid as well as grid connected PV and other alternative energy systems. Loss of mains detection software is available.

**System configuring**

- In case of a stand-alone application, if settings have to be changed, this can be done in a matter of minutes with a DIP switch setting procedure.
- Parallel and three phase applications can be configured with VE.Bus Quick Configure and VE.Bus System Configurator software.
- Off grid, grid interactive and self-consumption applications, involving grid-tie inverters and/or MPPT Solar Chargers can be configured with Assistants (dedicated software for specific applications).

**On-site Monitoring and control**

Several options are available: Battery Monitor, Multi Control Panel, Ve.Net Blue Power panel, Color Control panel, smartphone or tablet (Bluetooth Smart), laptop or computer (USB or RS232).

**Remote Monitoring and control**

Victron Ethernet Remote, Victron Global Remote and the Color Control Panel.

Data can be stored and displayed on our VRM (Victron Remote Management) website, free of charge.

**Remote configuring**

When connected to the Ethernet, systems with a Color Control panel can be accessed and settings can be changed.



Color Control panel, showing a PV application

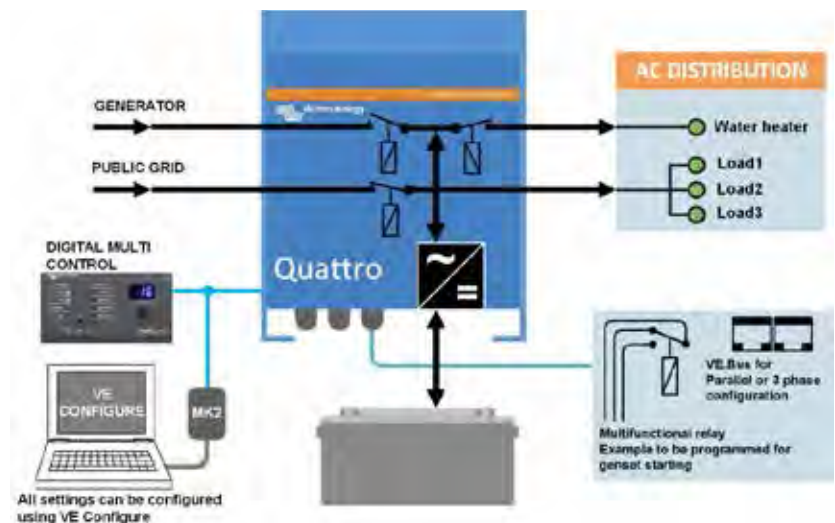

Quattro	12/3000/120-50/50 24/3000/70-50/50	12/5000/220-100/100 24/5000/120-100/100 48/5000/70-100/100	24/8000/200-100/100 48/8000/110-100/100	48/10000/140-100/100
PowerControl / PowerAssist	Yes			
Integrated Transfer switch	Yes			
AC inputs (2x)	Input voltage range: 187-265 VAC Input frequency: 45 – 65 Hz Power factor: 1			
Maximum feed through current (A)	2x 50	2x100	2x100	2x100
<b>INVERTER</b>				
Input voltage range (V DC)	9,5 – 17V 19 – 33V 38 – 66V			
Output (1)	Output voltage: 230 VAC ± 2% Frequency: 50 Hz ± 0,1%			
Cont. output power at 25°C (VA) (3)	3000	5000	8000	10000
Cont. output power at 25°C (W)	2500	4500	7000	9000
Cont. output power at 40°C (W)	2200	4000	6300	8000
Peak power (W)	6000	10000	16000	20000
Maximum efficiency (%)	93 / 94	94 / 94 / 95	94 / 96	96
Zero load power (W)	15 / 15	25 / 25 / 25	30 / 35	35
Zero load power in AES mode (W)	10 / 10	20 / 20 / 20	25 / 30	30
Zero load power in Search mode (W)	4 / 5	5 / 5 / 6	8 / 10	10
<b>CHARGER</b>				
Charge voltage 'absorption' (V DC)	14,4 / 28,8	14,4 / 28,8 / 57,6	28,8 / 57,6	57,6
Charge voltage 'float' (V DC)	13,8 / 27,6	13,8 / 27,6 / 55,2	27,6 / 55,2	55,2
Storage mode (V DC)	13,2 / 26,4	13,2 / 26,4 / 52,8	26,4 / 52,8	52,8
Charge current house battery (A) (4)	120 / 70	220 / 120 / 70	200 / 110	140
Charge current starter battery (A)	4 (12 V and 24 V models only)			
Battery temperature sensor	Yes			
<b>GENERAL</b>				
Auxiliary output (A) (5)	25	50	50	50
Programmable relay (6)	3x	3x	3x	3x
Protection (2)	a-g			
VE.Bus communication port	For parallel and three phase operation, remote monitoring and system integration			
General purpose com. port	2x	2x	2x	2x
Remote on-off	Yes			
Common Characteristics	Operating temp.: -20 to +50 °C Humidity (non-condensing): max. 95%			
<b>ENCLOSURE</b>				
Common Characteristics	Material & Colour: aluminium (blue RAL 5012) Protection category: IP 21			
Battery-connection	Four M8 bolts (2 plus and 2 minus connections)			
230 V AC-connection	Screw terminals 13 mm <sup>2</sup> (6 AWG)	Bolts M6	Bolts M6	Bolts M6
Weight (kg)	19	34 / 30 / 30	45/41	45
Dimensions (hwxwd in mm)	362 x 258 x 218	470 x 350 x 280 444 x 328 x 240 444 x 328 x 240	470 x 350 x 280	470 x 350 x 280
<b>STANDARDS</b>				
Safety	EN-IEC 60335-1, EN-IEC 60335-2-29, IEC 62109-1			
Emission, Immunity	EN 55014-1, EN 55014-2, EN 61000-3-3, EN 61000-6-3, EN 61000-6-2, EN 61000-6-1			
Automotive Directive	2004/104/EC			
Anti-islanding	See our website			
1) Can be adjusted to 60 HZ; 120 V 60 Hz on request				
2) Protection key:	3) Non-linear load, crest factor 3:1			
a) output short circuit	4) At 25 °C ambient			
b) overload	5) Switches off when no external AC source available			
c) battery voltage too high	6) Programmable relay that can a.o. be set for general alarm,			
d) battery voltage too low	DC under voltage or genset start/stop function			
e) temperature too high	AC rating: 230 V / 4 A			
f) 230 VAC on inverter output	DC rating: 4 A up to 35 VDC, 1 A up to 60 VDC			
g) input voltage ripple too high				



### Digital Multi Control Panel

A convenient and low cost solution for remote monitoring, with a rotary knob to set PowerControl and PowerAssist levels.



### Blue Power Panel

Connects to a Multi or Quattro and all VE.Net devices, in particular the VE.Net Battery Controller.

Graphical display of currents and voltages.



### Computer controlled operation and monitoring

Several interfaces are available:

- **MK2.2 VE.Bus to RS232 converter**  
Connects to the RS232 port of a computer (see 'A guide to VEConfigure')
- **MK2-USB VE.Bus to USB converter**  
Connects to a USB port (see 'A guide to VEConfigure')
- **VE.Net to VE.Bus converter**  
Interface to VE.Net (see VE.Net documentation)
- **VE.Bus to NMEA 2000 converter**
- **Victron Global Remote**  
The Global Remote is a modem which sends alarms, warnings and system status reports to cellular phones via text messages (SMS). It can also log data from Victron Battery Monitors, Multis, Quattros and Inverters to our VRM website through a GPRS connection. Access to this website is free of charge.
- **Victron Ethernet Remote**  
To connect to the Ethernet.
- **Color Control panel (see picture on page 1)**  
Behind the color LCD a Linux microcomputer runs open source software. The Color Control (CCGX) provides intuitive control and monitoring for all products connected to it. The list of Victron products that can be connected is endless: Inverters, Multis, Quattros, all our latest MPPT solar chargers, BMV-700, BMV-600, Lynx Ion + Shunt and more. The information can also be forwarded to our free remote monitoring website: the VRM Online Portal.

### BMV Battery Monitor

The BMV Battery Monitor features an advanced microprocessor control system combined with high resolution measuring systems for battery voltage and charge/discharge current. Besides this, the software includes complex calculation algorithms, like Peukert's formula, to exactly determine the state of charge of the battery. The BMV selectively displays battery voltage, current, consumed Ah or time to go. The monitor also stores a host of data regarding performance and use of the battery. Several models available (see battery monitor documentation).



MultiPlus  
24/3000/70

**Multifunctional, with intelligent power management**

The MultiPlus is a powerful true sine wave inverter, a sophisticated battery charger that features adaptive charge technology, and a high-speed AC transfer switch in a single compact enclosure. Next to these primary functions, the MultiPlus has several advanced features, as outlined below.

**Two AC Outputs**

The main output has no-break functionality. The MultiPlus takes over the supply to the connected loads in the event of a grid failure or when shore-/generator power is disconnected. This happens so fast (less than 20 milliseconds) that computers and other electronic equipment will continue to operate without disruption.

The second output is live only when AC is available on the input of the MultiPlus. Loads that should not discharge the battery, like a water heater for example, can be connected to this output (second output available on models rated at 3kVA and more).

**Virtually unlimited power thanks to parallel operation**

Up to six Multis can operate in parallel to achieve higher power output. Six 24/3000/70 units, for example, provide 15kW / 18kVA output power with 420 Amps of charging capacity.

**Three phase capability**

In addition to parallel connection, three units can be configured for three-phase output. But that's not all: with three strings of six parallel units a 45 kW / 54 kVA three-phase inverter and 1260 A charger can be built.

**Split phase options**

Two units can be stacked to provide 120-0-120V, and additional units can be paralleled up to a total of 6 units per phase, to supply up to 30 kW / 36 kVA of split phase power.

Alternatively, a split phase AC source can be obtained by connecting our autotransformer (see data sheet on [www.victronenergy.com](http://www.victronenergy.com)) to a 'European' inverter programmed to supply 240 V / 60 Hz.

**PowerControl - Dealing with limited generator, shore side or grid power**

The MultiPlus is a very powerful battery charger. It will therefore draw a lot of current from the generator or shore side supply (nearly 20 A per 3 kVA MultiPlus at 120 VAC). With the Multi Control Panel a maximum generator or shore current can be set. The MultiPlus will then take account of other AC loads and use whatever is extra for charging, thus preventing the generator or shore supply from being overloaded.

**PowerAssist - Boosting the capacity of shore or generator power**

This feature takes the principle of PowerControl to a further dimension. It allows the MultiPlus to supplement the capacity of the alternative source. Where peak power is so often required only for a limited period, the MultiPlus will make sure that insufficient shore or generator power is immediately compensated for by power from the battery. When the load reduces, the spare power is used to recharge the battery.

**Four stage adaptive charger and dual bank battery charging**

The main output provides a powerful charge to the battery system by means of advanced 'adaptive charge' software. The software fine-tunes the three stage automatic process to suit the condition of the battery, and adds a fourth stage for long periods of float charging. The adaptive charge process is described in more detail on the Phoenix Charger datasheet and on our website, under Technical Information. In addition to this, the MultiPlus will charge a second battery using an independent trickle charge output intended for a main engine or generator starter battery.

**System configuring has never been easier**

After installation, the MultiPlus is ready to go.

If settings have to be changed, this can be done in a matter of minutes with a DIP switch setting procedure. Even parallel and 3-phase operation can be programmed with DIP switches: no computer needed!

Alternatively, VE.Net can be used instead of the DIP switches.

And sophisticated software (VE.Bus Quick Configure and VE.Bus System Configurator) is available to configure several new, advanced, features.



MultiPlus Compact  
12/2000/80

PowerAssist with 2x MultiPlus in parallel

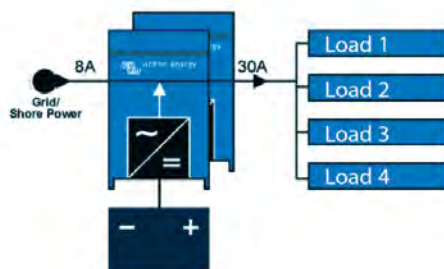

Five parallel units: output power 12,5 kW

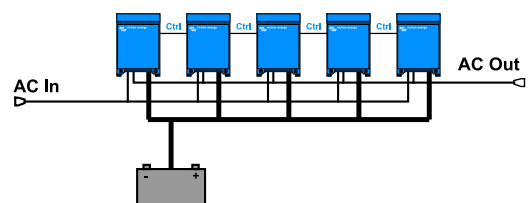



MultiPlus	12 Volt 24 Volt	12/2000/80 24/2000/50	12/3000/120 24/3000/70
PowerControl			Yes
PowerAssist			Yes
Transfer switch (A)			50
Parallel and 3-phase operation			Yes
<b>INVERTER</b>			
Input voltage range (V DC)		9,5 – 17 V	19 – 33 V
Output		Output voltage: 120 VAC ± 2%	Frequency: 60 Hz ± 0,1% (1)
Cont. output power at 75°F (VA) (3)		2000	3000
Cont. output power at 75°F (W)		1600	2500
Cont. output power at 100°F (W)		1450	2200
Peak power (W)		4000	6000
Maximum efficiency (%)		92 / 94	93 / 94
Zero load power (W)		9 / 11	15 / 15
Zero load power in AES mode (W)		7 / 8	10 / 10
Zero load power in Search mode (W)		3 / 4	4 / 5
<b>CHARGER</b>			
AC Input		Input voltage range: 95-140 VAC	Input frequency: 45 – 65 Hz    Power factor: 1
Charge voltage 'absorption' (V DC)			14,4 / 28,8
Charge voltage 'float' (V DC)			13,8 / 27,6
Storage mode (V DC)			13,2 / 26,4
Charge current house battery (A) (4)		80 / 50	120 / 70
Charge current starter battery (A)			4
Battery temperature sensor			yes
<b>GENERAL</b>			
Auxiliary output (5)		n. a.	Yes (32A)
Programmable relay (6)		Yes (1x)	Yes (3x)
Protection (2)			a - g
VE.Bus communication port		For parallel and three phase operation, remote monitoring and system integration	
General purpose com. port (7)		n. a.	Yes (2x)
Remote on-off			Yes
Common Characteristics		Operating temp. range: 0 - 120°F (fan assisted cooling)	Humidity (non condensing): max 95%
<b>ENCLOSURE</b>			
Common Characteristics		Material & Colour: aluminium (blue RAL 5012)	Protection category: IP 21
Battery-connection		M8 bolts	M8 bolts (2 plus and 2 minus connections)
120 V AC-connection		Screw-terminal 6 AWG (13 mm <sup>2</sup> )	Screw-terminal 6 AWG (13mm <sup>2</sup> )
Weight		13 kg 25 lbs.	19kg 40 lbs.
Dimensions (hwxwd in mm and inches)		520x255x125 mm 20.5x10.0x5.0 inch	362x258x218 mm 14.3x10.2x8.6 inch
<b>STANDARDS</b>			
Safety		EN 60335-1, EN 60335-2-29	
Emission Immunity		EN 55014-1, EN 55014-2, EN 61000-3-3	
1) Can be adjusted to 60 HZ; 120 V 60 Hz on request		3) Non linear load, crest factor 3:1	
2) Protection key:		4) At 75° F ambient	
a) output short circuit		5) Switches off when no external AC source available	
b) overload		6) Programmable relay that can a.o. be set for general alarm,	
c) battery voltage too high		DC under voltage or genset start/stop function	
d) battery voltage too low		AC rating: 230 V/4 A	
e) temperature too high		DC rating: 4A up to 35VDC, 1A up to 60VDC	
f) 230 VAC on inverter output		7) A.o. to communicate with a Lithium Ion battery BMS	
g) input voltage ripple too high			



### Digital Multi Control

A convenient and low cost solution for remote monitoring, with a rotary knob to set PowerControl and PowerAssist levels.



### Blue Power Panel

Connects to a Multi or Quattro and all VE.Net devices, in particular the VE.Net Battery Controller.

Graphic display of currents and voltages.



### Computer controlled operation and monitoring

Several interfaces are available:

- **MK2.2 VE.Bus to RS232 converter**  
Connects to the RS232 port of a computer (see 'A guide to VEConfigure')
- **MK2-USB VE.Bus to USB converter**  
Connects to a USB port (see 'A guide to VEConfigure')
- **VE.Net to VE.Bus converter**  
Interface to VE.Net (see VE.Net documentation)
- **VE.Bus to NMEA 2000 converter**
- **Victron Global Remote**  
The Global Remote is a modem which sends alarms, warnings and system status reports to cellular phones via text messages (SMS). It can also log data from Victron Battery Monitors, Multis, Quattros and Inverters to a website through a GPRS connection. Access to this website is free of charge.
- **Victron Ethernet Remote**  
To connect to Ethernet.



### BMV Battery Monitor

The BMV Battery Monitor features an advanced microprocessor control system combined with high resolution measuring systems for battery voltage and charge/discharge current. Besides this, the software includes complex calculation algorithms, like Peukert's formula, to exactly determine the state of charge of the battery. The BMV selectively displays battery voltage, current, consumed Ah or time to go. The monitor also stores a host of data regarding performance and use of the battery.

**Two AC inputs with integrated transfer switch**

The Quattro can be connected to two independent AC sources, for example shore-side power and a generator, or two generators. The Quattro will automatically connect to the active source.

**Two AC Outputs**

The main output has no-break functionality. The Quattro takes over the supply to the connected loads in the event of a grid failure or when shore/generator power is disconnected. This happens so fast (less than 20 milliseconds) that computers and other electronic equipment will continue to operate without disruption.

The second output is live only when AC is available on one of the inputs of the Quattro. Loads that should not discharge the battery, like a water heater for example, can be connected to this output.

**Virtually unlimited power thanks to parallel operation**

Up to 10 Quattro units can operate in parallel. Ten units 48/5000/70, for example, will provide 45 kW / 50 kVA output power and 700 Amps charging capacity.

**Three phase capability**

Three units can be configured for three-phase output. But that's not all: up to 10 sets of three units can be parallel connected to provide 135kW / 150kVA inverter power and more than 2000A charging capacity.

**Split phase options**

Two units can be stacked to provide 120-0-120 V, and additional units can be paralleled up to a total of 6 units per phase, to supply up to 30 kW / 36 kVA of split phase power.

Alternatively, a split phase AC source can be obtained by connecting our autotransformer (see data sheet on [www.victronenergy.com](http://www.victronenergy.com)) to a 'European' inverter programmed to supply 240 V / 60Hz.

**PowerControl – Dealing with limited generator, shore-side or grid power**

The Quattro is a very powerful battery charger. It will therefore draw a lot of current from the generator or shore side supply (Up to 40 A per 5 kVA Quattro at 120 VAC). A current limit can be set on each AC input. The Quattro will then take account of other AC loads and use whatever is spare for charging, thus preventing the generator or shore supply from being overloaded.

**PowerAssist – Boosting shore or generator power**

This feature takes the principle of PowerControl to a further dimension allowing the Quattro to supplement the capacity of the alternative source. Where peak power is so often required only for a limited period, the Quattro will make sure that insufficient shore or generator power is immediately compensated for by power from the battery. When the load reduces, the spare power is used to recharge the battery.

**Solar energy: AC power available even during a grid failure**

The Quattro can be used in off grid as well as grid connected PV and other alternative energy systems.

**System configuring has never been easier**

After installation, the Quattro is ready to go.

If settings have to be changed, this can be done in a matter of minutes with a new DIP switch setting procedure. Even parallel and 3-phase operation can be programmed with DIP switches: no computer needed!

Alternatively, VE.Net can be used instead of the DIP switches.

And sophisticated software (VE.Bus Quick Configure and VE.Bus System Configurator) is available to configure several new, advanced, features.



Quattro  
24/5000/120-100/100

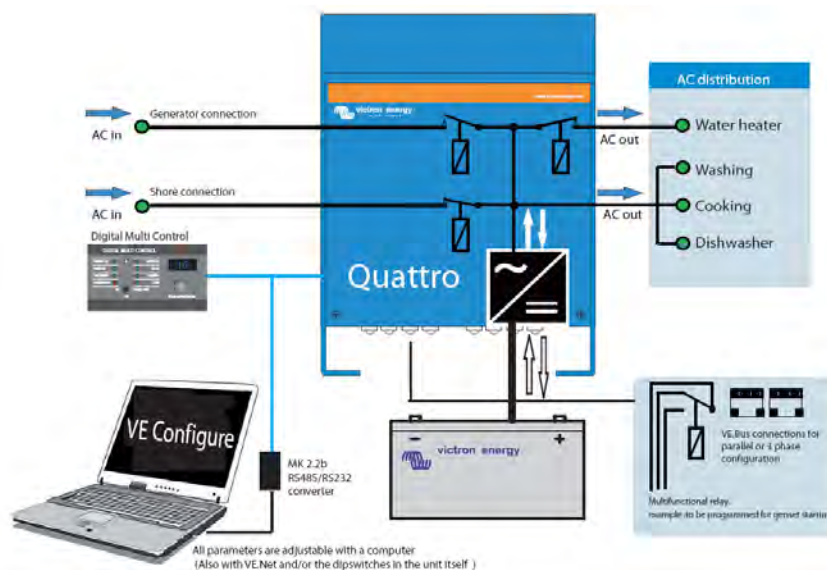

Quattro	12/5000/200-100/100 120 V	24/5000/120-100/100 120 V	48/3000/35-50/50 120 V	48/5000/70-100/100 120 V
PowerControl / PowerAssist	Yes			
Integrated Transfer switch	Yes			
AC inputs (2x)	Input voltage range: 90-140 VAC Input frequency: 45-65 Hz Power factor: 1			
Maximum feed through current (A)	2x100	2x100	2x50	2x100
<b>INVERTER</b>				
Input voltage range (V DC)	9,5 - 17	19 - 33	37,2 - 64,4	37,2 - 64,4
Output (1)	Output voltage: 120 VAC $\pm$ 2% Frequency: 60 Hz $\pm$ 0,1%			
Cont. output power at 25°C (VA) (3)	5000	5000	3000	5000
Cont. output power at 25°C (W)	4500	4500	2500	4500
Cont. output power at 40°C (W)	4000	4000	2200	4000
Peak power (W)	10000	10000	6000	10000
Maximum efficiency (%)	94	94	94	95
Zero load power (W)	25	25	15	25
Zero load power in AES mode (W)	20	20	10	20
Zero load power in Search mode (W)	5	5	5	6
<b>CHARGER</b>				
Charge voltage 'absorption' (V DC)	14,4	28,8	57,6	57,6
Charge voltage 'float' (V DC)	13,8	27,6	55,2	55,2
Storage mode (V DC)	13,2	26,4	52,8	52,8
Charge current house battery (A) (4)	200	120	35	70
Charge current starter battery (A)	4	4	n. a.	n. a.
Battery temperature sensor	Yes			
<b>GENERAL</b>				
Auxiliary output (A) (5)	50	50	32	50
Programmable relay (6)	3x	3x	3x	3x
Protection (2)	a-g			
VE.Bus communication port	For parallel and three phase operation, remote monitoring and system integration			
General purpose com. port (7)	Yes, 2x			
Remote on-off	Yes			
Common Characteristics	Operating temp.: -20 to +50°C (0 - 120°F) Humidity (non-condensing): max. 95%			
<b>ENCLOSURE</b>				
Common Characteristics	Material & Colour: aluminium (blue RAL 5012) Protection category: IP 21			
Battery-connection	Four M8 bolts (2 plus and 2 minus connections)			
230 V AC-connection	M6 bolts	M6 bolts	Screw terminals 13 mm <sup>2</sup> (6 AWG)	M6 bolts
Weight (kg)	75 lb 34 kg	66 lb 30 kg	42 lb 19 kg	66 lb 30 kg
Dimensions (hwxwd)	18,5 x 14,0 x 11,2 inch 470 x 350 x 280 mm	17,5 x 13,0 x 9,6 inch 444 x 328 x 240 mm	14,3x10.2x8.6 inch 362x258x218 mm	17,5 x 13,0 x 9,6 inch 444 x 328 x 240 mm
<b>STANDARDS</b>				
Safety	EN 60335-1, EN 60335-2-29			
Emission, Immunity	EN 55014-1, EN 55014-2, EN 61000-3-3			
1) Can be adjusted to 50 Hz	3) Non-linear load, crest factor 3:1			
2) Protection key:	4) At 25°C ambient			
a) output short circuit	5) Switches off when no external AC source available			
b) overload	6) Programmable relay that can be set for general alarm, DC under voltage or genset start/stop function			
c) battery voltage too high	AC rating: 120 V / 4 A			
d) battery voltage too low	DC rating: 4 A up to 35 VDC, 1 A up to 60 VDC			
e) temperature too high	7) A.o. to communicate with a Lithium-Ion battery BMS			
f) 120 VAC on inverter output				
g) input voltage ripple too high				



### Digital Multi Control

A convenient and low cost solution for remote monitoring, with a rotary knob to set PowerControl and PowerAssist levels.



### Blue Power Panel

Connects to a Multi or Quattro and all VE.Net devices, in particular the VE.Net Battery Controller. Graphic display of currents and voltages.



### Computer controlled operation and monitoring

Several interfaces are available:

- **MK2.2 VE.Bus to RS232 converter**  
Connects to the RS232 port of a computer (see 'A guide to VEConfigure')
- **MK2-USB VE.Bus to USB converter**  
Connects to a USB port (see 'A guide to VEConfigure')
- **VE.Net to VE.Bus converter**  
Interface to VE.Net (see VE.Net documentation)
- **VE.Bus to NMEA 2000 converter**
- **Victron Global Remote**  
The Global Remote is a modem which sends alarms, warnings and system status reports to cellular phones via text messages (SMS). It can also log data from Victron Battery Monitors, Multis, Quattros and Inverters to a website through a GPRS connection. Access to this website is free of charge.
- **Victron Ethernet Remote**  
To connect to Ethernet.



### BMV Battery Monitor

The BMV Battery Monitor features an advanced microprocessor control system combined with high resolution measuring systems for battery voltage and charge/discharge current. Besides this, the software includes complex calculation algorithms, like Peukert's formula, to exactly determine the state of charge of the battery. The BMV selectively displays battery voltage, current, consumed Ah or time to go. The monitor also stores a host of data regarding performance and use of the battery.



## Blue Power IP 65 Charger

Blue Power Charger IP65	12 V 5/7/10/15 A	24 V 5/8 A
Input voltage range	180-265 VAC	
Efficiency	94%	95%
Standby power consumption	0,5 W	
Charge voltage 'absorption'	Normal: 14,4 V High: 14,7 V Li-ion: 14,2 V	Normal: 28,8 V High: 29,4 V Li-ion: 28,4 V
Charge voltage 'float'	Normal: 13,8 V High: 13,8 V Li-ion: 13,5 V	Normal: 27,6 V High: 27,6 V Li-ion: 27,0 V
Charge voltage 'storage'	Normal: 13,2 V High: 13,2 V Li-ion: 13,5 V	Normal: 26,4 V High: 26,4 V Li-ion: 27,0 V
Charge current	5 / 7 / 10 / 15 A	5 / 8 A
Low current mode	2 / 2 / 3 / 4 A	2 / 3 A
Temperature compensation (lead-acid batteries only)	16 mV/°C	32 mV/°C
Can be used as power supply	Yes	
Back current drain	0,7 Ah/month (1 mA)	
Protection	Reverse polarity    Output short circuit Over temperature	
Operating temp. range	-30 to +50°C (full rated output up to 30°C) (cables retain flexibility at low temperature)	
Humidity (non condensing)	Max 95 %	
<b>ENCLOSURE</b>		
Battery-connection	Black and red cable of 1,5 meter with 20 A DC connector, clamps and M8 eyelets	
230 V AC-connection	Cable of 1,5 meter with CEE 7/17, BS 1363 plug (UK) or AS/NZS 3112 plug	
Protection category	IP65 (splash and dust proof)	
Weight	0,9 kg	0,9 kg
Dimensions (h x w x d)	12/7: 47x95x190mm Other: 60x105x190mm	24/5: 47x95x190mm 24/8: 60x105x190mm
<b>STANDARDS</b>		
Safety	EN 60335-1, EN 60335-2-29	
Emission	EN 55014-1, EN 61000-6-3, EN 61000-3-2	
Immunity	EN 55014-2, EN 61000-6-1, EN 61000-6-2, EN 61000-3-3	
<a href="http://www.victronenergy.com">www.victronenergy.com</a> Customer support: <a href="mailto:sales@victronenergy.com">sales@victronenergy.com</a>		

### Included

#### Clamps

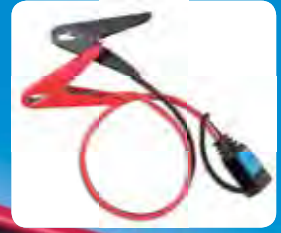

#### M8 eyelets



### Optional

#### Fused clamps



#### Fused M6 eyelets



#### Extension cable, 2 m



#### Autoplug



# Blue Power Charger

IP65

The professional's choice

5  
Year  
WARRANTY



- Water, dust and chemical resistant
- Seven step smart charge algorithm
- Recovery of fully discharged 'dead' batteries
- Automatic power supply function
- Severe cold performance: down to -30°C
- Several other battery life enhancing features
- Low power mode to charge smaller batteries
- **Li-ion** battery mode



# IP65 - Charger Guide

Blue Power IP65 Charger



Battery size Ah	12V				24V	
	5 A 20 - 50 Ah	7 A 20 - 50 Ah	10 A 30 - 70 Ah	15 A 50 - 150 Ah	5 A 20 - 50 Ah	8 A 30 - 70 Ah
Your IP65 Charger »	12/5	12/7	12/10	12/15	24/5	24/8
MOTORCYCLE	Recommended	OK	OK	OK		
CLASSIC	Recommended	Recommended	OK	OK		
MODERN	Recommended	Recommended	Recommended	Recommended		
	Recommended	Recommended	Recommended	Recommended	OK	OK
					Recommended	Recommended
	OK	OK	OK	Recommended	OK	Recommended

**Recommended**

This is the best charger for this type of battery. The battery will be charged in the most efficient way.

**OK**

This charger can be used for this battery. It is possible that it takes longer to charge the battery than using a recommended charger for this type of battery.

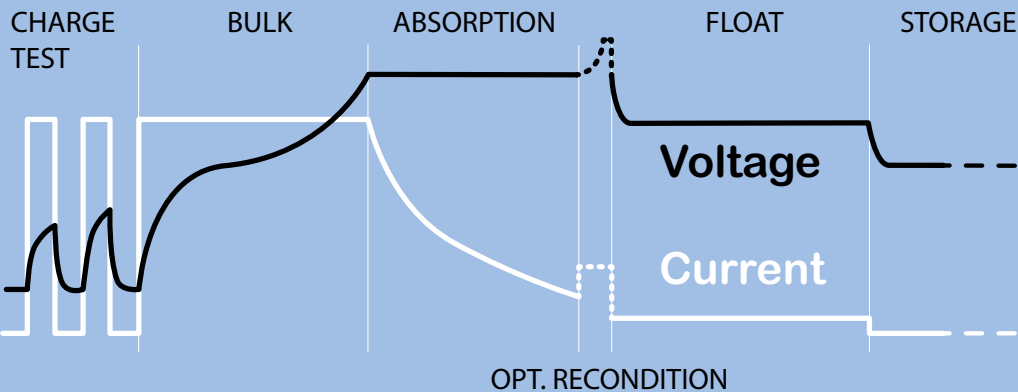

## Reconditioning

A lead-acid battery that has been insufficiently charged or has been left discharged during days or weeks will deteriorate due to sulfation. If caught in time, sulfation can sometimes be partially reversed by charging the battery with low current up to a higher voltage.

## Recovery function for fully discharged batteries

Most reverse polarity protected chargers will not recognize, and therefore not recharge a battery which has been discharged to zero or nearly zero Volts. The **Blue Power Charger** however will attempt to recharge a fully discharged battery with low current and resume normal charging once sufficient voltage has developed across the battery terminals.





### Ultra high efficiency “green” battery charger

With up to 95% efficiency, these chargers generate up to four times less heat when compared to the industry standard. And once the battery is fully charged, power consumption reduces to 0,5 Watt, some five to ten times better than the industry standard.

### Durable, safe and silent

- Low thermal stress on the electronic components.
- Protection against ingress of dust, water and chemicals.
- Protection against overheating: the output current will reduce as temperature increases up to 60°C, but the charger will not fail.
- The chargers are totally silent: no cooling fan or any other moving parts.

### Storage mode: less corrosion of the positive plates

Even the lower float charge voltage that follows the absorption period will cause grid corrosion. It is therefore essential to reduce the charge voltage even further when the battery remains connected to the charger during more than 48 hours.

STORAGE

REFRESH

STORAGE



1 week

### Temperature compensated charging

The optimal charge voltage of a lead-acid battery varies inversely with temperature.

**The Blue Power IP65 Charger** measures ambient temperature during the test phase and compensates for temperature during the charge process. The temperature is measured again when the charger is in low current mode during float or storage. Special settings for a cold or hot environment are therefore not needed.

### Li-ion battery mode

The **Blue Power Charger** uses a specific charging algorithm for Li-ion (LiFePO<sub>4</sub>) batteries, with automatic Li-ion under voltage protection reset.



**Skylla-i 24/100 (3)**

**Skylla-i 24/100 (1+1)**

### **Skylla-i (1+1): two outputs to charge 2 battery banks**

The Skylla-i (1+1) features 2 isolated outputs. The second output, limited to approximately 4 A and with a slightly lower output voltage, is intended to top up a starter battery.

### **Skylla-i (3): three full current outputs to charge 3 battery banks**

The Skylla-i (3) features 3 isolated outputs. All outputs can supply the full rated output current.

#### **Rugged**

Aluminium epoxy powder coated cases with drip shield and stainless steel fixings withstand the rigors of an adverse environment: heat, humidity and salt air.

Circuit boards are protected with an acrylic coating for maximum corrosion resistance.

Temperature sensors ensure that power components will always operate within specified limits, if needed by automatic reduction of output current under extreme environmental conditions.

#### **Flexible**

Next to a CAN bus (NMEA2000) interface, a rotary switch, DIP switches and potentiometers are available to adapt the charge algorithm to a particular battery and its conditions of use.

Please refer to the manual for a complete overview of the possibilities.

#### **Important features:**

##### **Synchronised parallel operation**

Several chargers can be synchronised with the CAN bus interface. This is achieved by simply interconnecting the chargers with RJ45 UTP-cables. Please see the manual for details.

##### **The right amount of charge for a lead-acid battery: variable absorption time**

When only shallow discharges occur the absorption time is kept short in order to prevent overcharging of the battery. After a deep discharge the absorption time is automatically increased to make sure that the battery is completely recharged.

##### **Preventing damage due to excessive gassing: the BatterySafe mode**

If, in order to quickly charge a battery, a high charge current in combination with a high absorption voltage has been chosen, the Skylla-i will prevent damage due to excessive gassing by automatically limiting the rate of voltage increase once the gassing voltage has been reached.

##### **Less maintenance and aging when the battery is not in use: the Storage mode**

The storage mode kicks in whenever the battery has not been subjected to discharge during 24 hours. In the storage mode float voltage is reduced to 2,2 V/cell (26,4 V for 24 V battery) to minimise gassing and corrosion of the positive plates. Once a week the voltage is raised back to the absorption level to 'refresh' the battery. This feature prevents stratification of the electrolyte and sulphation, a major cause of early battery failure.

##### **To increase battery life: temperature compensation**

Every Skylla-i comes with a battery temperature sensor. When connected, charge voltage will automatically decrease with increasing battery temperature. This feature is especially recommended for sealed lead-acid batteries and/or when important fluctuations of battery temperature are expected.

##### **Battery voltage sense**

In order to compensate for voltage loss due to cable resistance, the Skylla-i is provided with a voltage sense facility so that the battery always receives the correct charge voltage.

##### **Suitable for AC and DC supply (AC-DC and DC-DC operation)**

The chargers also accept a DC supply.

##### **Use as a power supply**

As a result of the perfectly stabilized output voltage, the Skylla-i can be used as a power supply if batteries or large buffer capacitors are not available.

##### **Li-Ion (LiFePO4) ready**

Simple charger on-off control can be implemented by connecting a relay or open collector optocoupler output from a Li-Ion BMS to the remote control port of the charger. Alternatively complete control of voltage and current can be achieved by connecting to the galvanically isolated CAN bus port.

##### **Learn more about batteries and battery charging**

To learn more about batteries and charging batteries, please refer to our book 'Energy Unlimited' (available free of charge from Victron Energy and downloadable from [www.victronenergy.com](http://www.victronenergy.com)).

Skylla-i	24/80 (1+1)	24/80 (3)	24/100 (1+1)	24/100 (3)
Input voltage (VAC)	230 V			
Input voltage range (VAC)	185-265 V			
Input voltage range (VDC)	180-350 V			
Maximum AC input current @ 180 VAC	16 A		20 A	
Frequency (Hz)	45-65 Hz			
Power factor	0,98			
Charge voltage 'absorption' (VDC) (1)	28,8 V			
Charge voltage 'float' (VDC)	27,6 V			
Charge voltage 'storage' (VDC)	26,4 V			
Charge current (A) (2)	80 A	3 x 80 A (max total output: 80A)	100 A	3 x 100 A (max total output: 100A)
Charge current starter batt. (A)	4 A	n. a.	4	n. a.
Charge algorithm	7 stage adaptive			
Battery capacity (Ah)	400-800 Ah		500-1000 Ah	
Charge algorithm, Li-Ion	3 stage, with on-off control or CAN bus control			
Temperature sensor	Yes			
Can be used as power supply	Yes			
Remote on-off port	Yes (can be connected to a Li-Ion BMS)			
CAN bus communication port (VE.Can)	Two RJ45 connectors, NMEA2000 protocol, galvanically isolated			
Synchronised parallel operation	Yes, with VE.Can			
Alarm relay	DPST	AC rating: 240VAC/4A	DC rating: 4A up to 35VDC, 1A up to 60VDC	
Forced cooling	Yes			
Protection	Battery reverse polarity (fuse)		Output short circuit	Over temperature
Operating temp. range	-20 to 60°C (Full output current up to 40°C)			
Humidity (non condensing)	max 95%			
<b>ENCLOSURE</b>				
Material & Colour	aluminium (blue RAL 5012)			
Battery-connection	M8 bolts			
230 VAC-connection	screw-clamp 10mm <sup>2</sup> (AWG 7)			
Protection category	IP 21			
Weight kg (lbs)	7 kg (16 lbs)			
Dimensions hxxwx d in mm (hxxwx d in inches)	405 x 250 x 150 mm (16.0 x 9.9 x 5.9 inch)			
<b>STANDARDS</b>				
Safety	EN 60335-1, EN 60335-2-29			
Emission	EN 55014-1, EN 61000-6-3, EN 61000-3-2			
Immunity	EN 55014-2, EN 61000-6-1, EN 61000-6-2, EN 61000-3-3			
1) Output voltage range 20-36 V. Can be set with rotary switch or potentiometers.		2) Up to 40°C (100°F) ambient. Output will reduce to 80% at 50°C, and to 60% at 60°C.		



### BMV 700 Battery Monitor

The BMV 700 Battery Monitor features an advanced microprocessor control system combined with high resolution measuring systems for battery voltage and charge/discharge current.

The software includes complex calculation algorithms, like Peukert's formula, to exactly determine the state of charge of the battery. The BMV 700 selectively displays battery voltage, battery current, consumed Ah or time to go.



### Skylla-i Control

The Skylla-i Control panel provides remote process control and monitoring of the charge process with LED status indication. In addition, the remote panel also offers input current adjustment that can be used to limit the input current and thus the power drawn from the AC supply. This is particularly useful when operating the charger from limited shore power or small gensets. The panel can also be used to change several battery charging parameters.

Several control panels can be connected to one charger or to a set of synchronised and parallel connected chargers.



## Skylla charger 24/48V



Skylla TG 24 50



Skylla TG 24 50 3 phase



Skylla TG 24 100

### Perfect chargers for any type of battery

Charge voltage can be precisely adjusted to suit any sealed or unsealed battery system.

In particular, sealed maintenance free batteries must be charged correctly in order to ensure a long service life. Overvoltage will result in excessive gassing and venting of a sealed battery. The battery will dry out and fail.

### Suitable for AC and DC supply (AC-DC and DC-DC operation)

Except for the 3-phase input models, the chargers also accept a DC supply.

### Controlled charging

Every TG Charger has a microprocessor, which accurately controls the charging in three steps. The charging process takes place in accordance with the IUoUo characteristic and charges more rapidly than other processes.

### Use of TG Chargers as a power supply

As a result of the perfectly stabilized output voltage, a TG Charger can be used as a power supply if batteries or large buffer capacitors are not available.

### Two outputs to charge 2 battery banks (24 V models only)

The TG Chargers feature 2 isolated outputs. The second output, limited to approximately 4 A and with a slightly lower output voltage, is intended to top up a starter battery.

### To increase battery life: temperature compensation

Every Skylla TG Charger comes with a battery temperature sensor. When connected, charge voltage will automatically decrease with increasing battery temperature. This feature is especially recommended for sealed batteries which otherwise might be overcharged and dry out due to venting.

### Battery voltage sense

In order to compensate for voltage loss due to cable resistance, TG Chargers are provided with a voltage sense facility so that the battery always receives the correct charge voltage.

### Learn more about batteries and battery charging

To learn more about batteries and charging batteries, please refer to our book 'Energy Unlimited' (available free of charge from Victron Energy and downloadable from [www.victronenergy.com](http://www.victronenergy.com)).

Charge curve

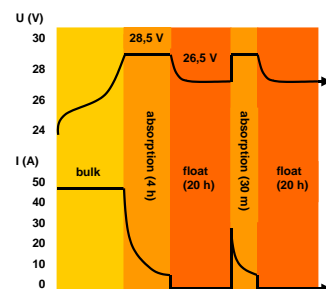

Application example

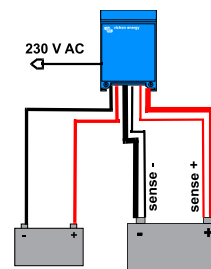

Skylla	24/30 TG 24/50 TG	24/50 TG 3 phase	24/80 TG	24/100 TG	24/100 TG 3 phase	48/25 TG	48/50 TG
Input voltage (V AC)	230	3 x 400	230	230	3 x 400	230	230
Input voltage range (V AC)	185-264	320-450	185-264	185-264	320-450	185-264	185-264
Input voltage range (V DC)	180-400	n. a.	180-400	180-400	n. a.	180-400	180-400
Frequency (Hz)	45-65						
Power factor	1						
Charge voltage 'absorption' (V DC)	28,5	28,5	28,5	28,5	28,5	57	57
Charge voltage 'float' (V DC)	26,5	26,5	26,5	26,5	26,5	53	53
Charge current house batt. (A) (2)	30 / 50	50	80	100	100	25	50
Charge current starter batt. (A)	4	4	4	4	4	n. a.	n. a.
Charge characteristic	IUoUo (three step)						
Battery capacity (Ah)	150-500	250-500	400-800	500-1000	500-1000	125-250	250-500
Temperature sensor	√						
Can be used as power supply	√						
Remote alarm	Potential free contacts 60 V / 1 A (1x NO and 1x NC)						
Forced cooling	√						
Protection (1)	a,b,c,d						
Operating temp. range	-20 to 60°C (0 - 140°F)						
Humidity (non condensing)	max 95%						
<b>ENCLOSURE</b>							
Material & Colour	aluminium (blue RAL 5012)						
Battery-connection	M8 studs						
230 V AC-connection	screw-clamp 2,5 mm <sup>2</sup> (AWG 6)						
Protection category	IP 21						
Weight kg (lbs)	5,5 (12.1)	13 (28)	10 (22)	10 (22)	23 (48)	5,5 (12.1)	10 (12.1)
Dimensions hwxwd in mm (hwxwd in inches)	365x250x147 (14.4x9.9x5.8)	365x250x257 (14.4x9.9x10.1)	365x250x257 (14.4x9.9x10.1)	365x250x257 (14.4x9.9x10.1)	515x260x265 (20x10.2x10.4)	365x250x147 (14.4x9.9x5.8)	365x250x257 (14.4x9.9x10.1)
<b>STANDARDS</b>							
Safety	EN 60335-1, EN 60335-2-29						
Emission	EN 55014-1, EN 61000-3-2						
Immunity	EN 55014-2, EN 61000-3-3						
1) Protection	c. Battery voltage too high						
a. Output short circuit	d. Temperature too high						
b. Battery reverse polarity detection							
2) Up to 40°C (100°F) ambient							



### BMV 700 Battery Monitor

The BMV 700 Battery Monitor features an advanced microprocessor control system combined with high resolution measuring systems for battery voltage and charge/discharge current. Besides this, the software includes complex calculation algorithms, like Peukert's formula, to exactly determine the state of charge of the battery. The BMV 700 selectively displays battery voltage, current, consumed Ah or time to go.

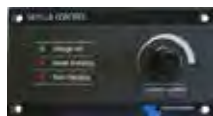

### Skylla Control

The Skylla Control allows you to alter the charge current and see the system status. Altering the charge current is useful if the shore power fuse is limited: the AC current drawn by the battery charger can be controlled by limiting the maximum output current, thereby preventing the shore power fuse from blowing.

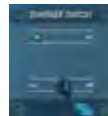

### Charger Switch

A remote on-off switch



### Battery Alarm

An excessively high or low battery voltage is indicated by an audible and visual alarm.

## Skylla TG charger 24V 90-265V GL approved



**Skylla Charger**  
24V 50A

### Universal 90-265V AC input voltage range and also suitable for DC supply

All models will operate without any adjustment needed over a 90 to 265 Volt input voltage range, whether 50 Hz or 60 Hz.

The chargers will also accept a 90-400V DC supply.

### Germanischer Lloyd approval

The Chargers have been approved by Germanischer Lloyd (GL) to environmental category C, EMC 1.

Category C applies to equipment protected from the weather.

EMC 1 applies to conducted and radiated emission limits for equipment installed on the bridge of a ship.

The approval to GL C, EMC1 implies that the Chargers also complies to IEC 60945-2002, category "protected" and "equipment installed on the bridge of a ship".

The GL certification applies to 185-265V AC supply.

### Other features

- Microprocessor control
- Can be used as power supply
- Battery temperature sensor for temperature compensated charging
- Battery voltage sensing to compensate for voltage loss due to cable resistance

### Other Skylla chargers

- Standard 185-265V AC models with additional output to charge a starter battery
- GMDSS models, with all required monitoring and alarm functions.

### Learn more about batteries and battery charging

To learn more about batteries and charging batteries, please refer to our book 'Energy Unlimited' (available free of charge from Victron Energy and downloadable from [www.victronenergy.com](http://www.victronenergy.com)).

### Charge curve

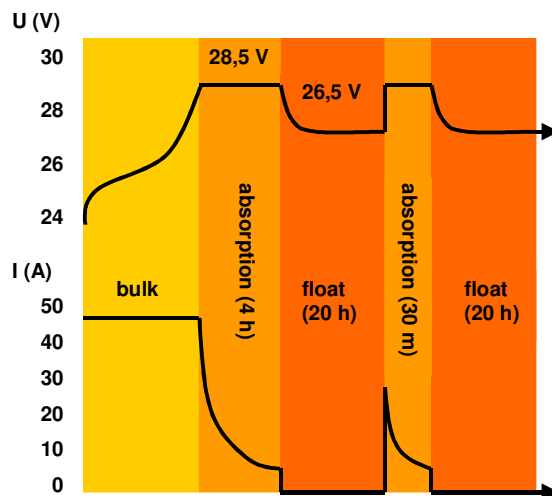

Skylla-TG	24/30 90-265 VAC	24/50 90-265 VAC	24/100-G 90-265 VAC
Input voltage (V AC)	230	230	230
Input voltage range (V AC)	90-265	90-265	90-265
Input voltage range (V DC)	90-400	90-400	90-400
Frequency (Hz)	45-65 Hz or DC		
Power factor	1		
Charge voltage 'absorption' (V DC)	28,5	28,5	28,5
Charge voltage 'float' (V DC)	26,5	26,5	26,5
Charge current house batt. (A) (2)	30 (limited to 22 A at 110V AC)	50	100
Charge current starter batt. (A)	4	4	4
Charge characteristic	IUoUo (three step)		
Battery capacity (Ah)	150-300	250-500	500-1000
Temperature sensor	√		
Can be used as power supply	√		
Remote alarm	Potential free contacts 60V / 1A (1x NO and 1x NC)		
Forced cooling	√		
Protection (1)	a,b,c,d		
Operating temp. range	-20 to 60°C (0 - 140°F)		
Humidity (non condensing)	max 95%		
<b>ENCLOSURE</b>			
Material & Colour	aluminium (blue RAL 5012)		
Battery-connection	M8 studs		
230 V AC-connection	screw-clamp 2,5 mm <sup>2</sup> (AWG 6)		
Protection category	IP 21		
Weight kg (lbs)	5,5 (12.1)	5,5 (12.1)	10 (22)
Dimensions hxwx d in mm (hxwx d in inches)	365x250x147 (14.4x9.9x5.8)	365x250x147 (14.4x9.9x5.8)	365x250x257 (14.4x9.9x10.1)
<b>STANDARDS</b>			
Vibration	0,7g (IEC 60945)		
Safety	EN 60335-1, EN 60335-2-29, IEC 60945		
Emission	EN 55014-1, EN 61000-3-2, IEC 60945		
Immunity	EN 55014-2, EN 61000-3-3, IEC 60945		
Germanischer Lloyd	Certificate 54 758 – 08HH		
1) Protection key: a) Output short circuit b) Battery reverse polarity detection	c) Battery voltage too high d) Temperature too high		2) Up to 40°C (100°F) ambient



#### BMV-600S Battery Monitor

The BMV – 600 Battery Monitor features an advanced microprocessor control system combined with high resolution measuring systems for battery voltage and charge/discharge current. Besides this, the software includes complex calculation algorithms, like Peukert's formula, to exactly determine the state of charge of the battery. The BMV – 600 selectively displays battery voltage, current, consumed Ah or time to go.



#### Skylla Control

The Skylla Control allows you to alter the charge current and see the system status. Altering the charge current is useful if the shore power fuse is limited: the AC current drawn by the battery charger can be controlled by limiting the maximum output current, thereby preventing the shore power fuse from blowing.

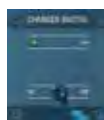

#### Charger Switch

A remote on-off switch



#### Battery Alarm

An excessively high or low battery voltage is indicated by an audible and visual alarm.



## Color Control GX



### Color Control GX

The Color Control (CCGX) provides intuitive control and monitoring for all products connected to it. The list of Victron products that can be connected is endless: Inverters, Multis, Quattros, all our latest MPPT solar chargers, BMV-700, BMV-600, Lynx Ion + Shunt and more.

### VRM Online Portal

Besides monitoring and controlling products on the CCGX, the information is also forwarded to our free remote monitoring website: the VRM Online Portal. To get an impression of the VRM Online Portal, visit <https://vrm.victronenergy.com>, and try our demo. See also the screenshots further down in this datasheet.

### Future functionality

The CCGX has endless possibilities. To implement all our ideas and wishes will take years. There are therefore many features that are not yet available. Functions marked with 'Future function' will become available later on, as a firmware update. Firmware updates are free of charge, as with all updates of Victron products. Updating the product is easy: the CCGX will update itself automatically, as long as it is connected to the internet. Manual updates can be done with a USB stick and microSD cards.

### Supported products

- Multis and Quattros, including split-phase and three-phase systems. Monitoring and control (on/off and current limiter). Changing settings is not yet available.
- BlueSolar MPPT 150/70 and the MPPT 150/85. Current solar output is visible on the overview screen, and all parameters are logged to the VRM online portal. Note that the VRM App has a nice overview showing data of the BlueSolar MPPT 150/70 as well. When multiple BlueSolar MPPTs with VE.Can are used in parallel, the Color Control will show all information as one. See also our blog-post about [synchronizing multiple MPPT 150/70 solar chargers](#).
- BlueSolar MPPT Solar Chargers with a VE.Direct port (70/15, 75/15, 100/15, 100/30, 75/50, 100/50, 150/35) can be connected to the VE.Direct ports on the CCGX. Connecting multiple at the same time is possible. They will all appear as a separate Solar Charger in the device list.
- BMV-700 family can be connected directly to the VE.Direct ports on the CCGX. Use the VE.Direct Cable for this. [See our pricelist](#).
- BMV-600 family can be connected to the VE.Direct ports on the CCGX. Use the VE.Direct to BMV60xS cable for that. [See our pricelist](#).
- Lynx Ion + Shunt
- Lynx Shunt VE.Can
- Skylla-i
- NMEA2000 tanksensors
- A USB GPS can be connected to the USB port. Location and speed will be visible on the display, and the data is sent to the VRM Portal for tracking purposes. The map on VRM will show the latest position.
- WiFi USB. [See our pricelist](#).

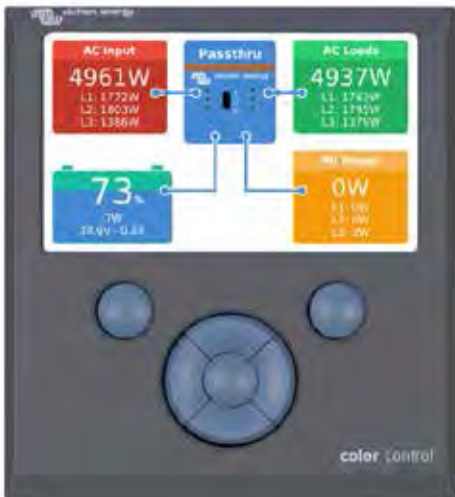

Note that there are more options for products which use the VE.Direct ports, such as BMVs and small MPPTs. They can also be connected through USB, useful when more than two products need to be connected. Use an off-the-shelf USB-hub and the VE.Direct to USB interface, ASS030530000.

### Other highlights

- When connected to the internet, the CCGX will update itself automatically when there is a new software version available.
- Multiple languages: English, Chinese, German, Italian, Spanish, French, Swedish and Dutch.
- Use the CCGX as a Modbus-TCP gateway to all connected Victron products. See our [Modbus-TCP FAQ](#) for more information.

### Notes for existing VGR2 and VER users

- Opposite to the Victron Global Remote 2 (VGR2) and Victron Ethernet Remote (VER), the CCGX stores all data locally during network interruptions. As soon as the connection to the VRM Online Portal is restored, it will automatically send all backlogged data to the portal. Data can then be analyzed on <https://vrm.victronenergy.com>.
- Remote VEConfigure is not yet supported by the CCGX. This functionality is expected in 2015 Q1. It will be even better than the VGR2 and VER: it will include support for changing Assistants and their settings.
- The local website, as present on the VER, is not yet supported.
- The CCGX has no internal GPRS modem: you cannot insert a sim-card into the CCGX. Use an off-the-shelf GPRS or 3G router instead. See the [blog post about 3G routers](#).

### More information

For help with installation please read the [Color Control GX Manual](#) and visit the [Frequently Asked Questions page](#).



Color Control GX			
Power supply voltage range	9 – 70 V DC		
<b>Current draw</b>	12 V DC	24 V DC	48 V DC
Switched off	0 mA	0 mA	0 mA
Display off	140 mA	80 mA	40 mA
Display at minimum intensity	160 mA	90 mA	45 mA
Display at maximum intensity	245 mA	125 mA	65 mA
Potential free contact	3A / 30V DC / 250V AC (Normally open)		
Communication ports			
VE.Direct	2 separate VE.Direct ports – isolated		
VE.Can	2 paralleled RJ45 sockets – isolated		
VE.Bus	2 paralleled RJ45 sockets – isolated		
USB	2 USB Host ports – not isolated		
Ethernet	10/100/1000MB RJ45 socket – isolated except shield		
3rd party interfacing			
Modbus-TCP	Use Modbus-TCP to monitor and control all products connected to the Color Control GX		
JSON	Use the VRM JSON API to retrieve data from the <a href="#">VRM Portal</a>		
Other			
Outer dimensions (h x w x d)	130 x 120 x 28 mm		
Operating temperature range	-20 to +50°C		

Overview - Multi with PV Inverter on output (Hub-2)

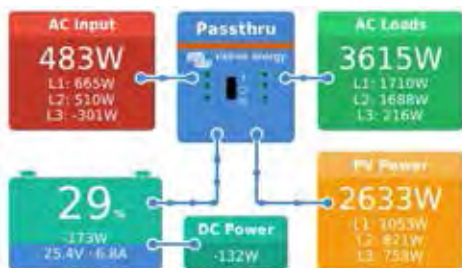

Main menu

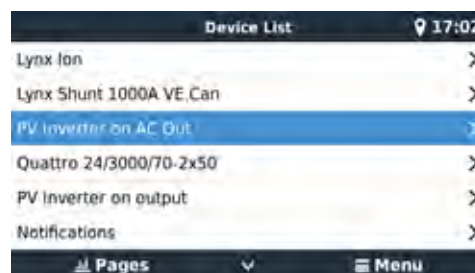

Overview - Multi

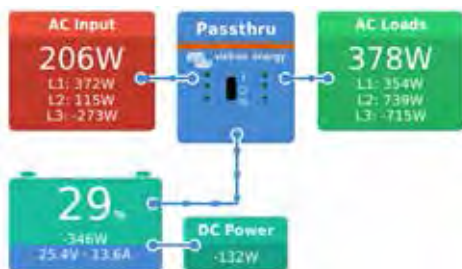

Alarm notifications

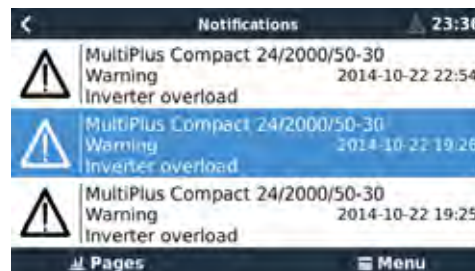

Overview - Multi with MPPT 150/70

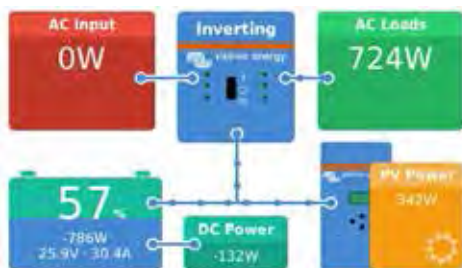

Tiles overview – Hub-2 system

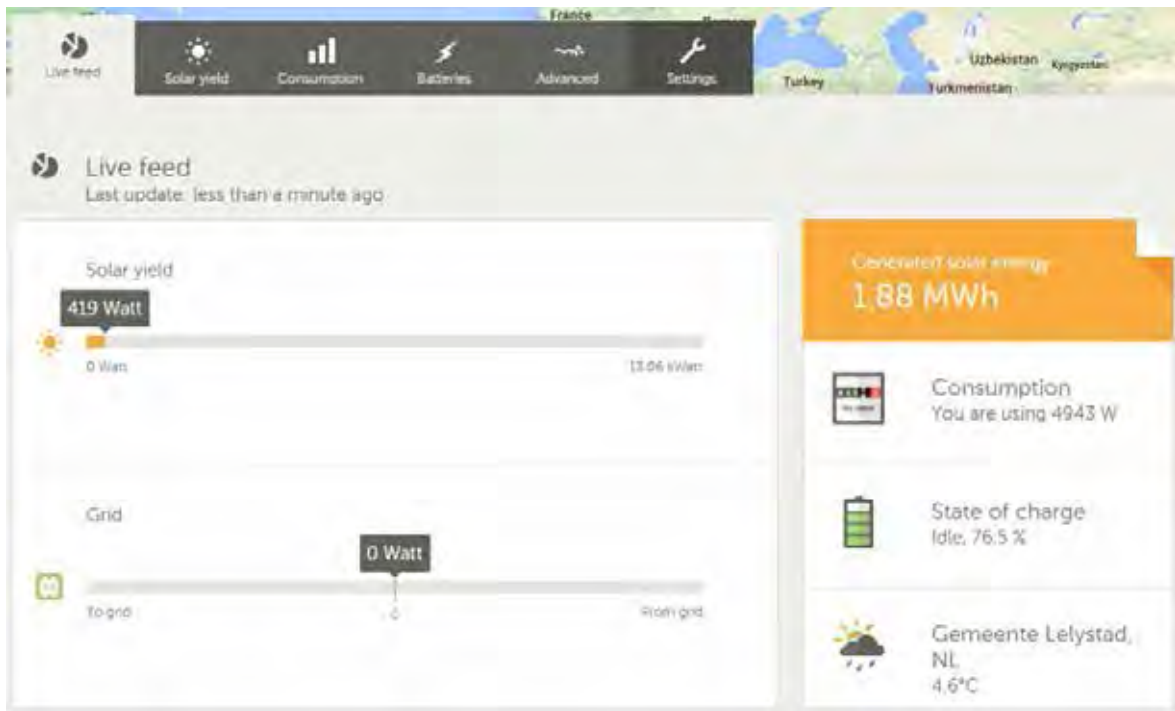
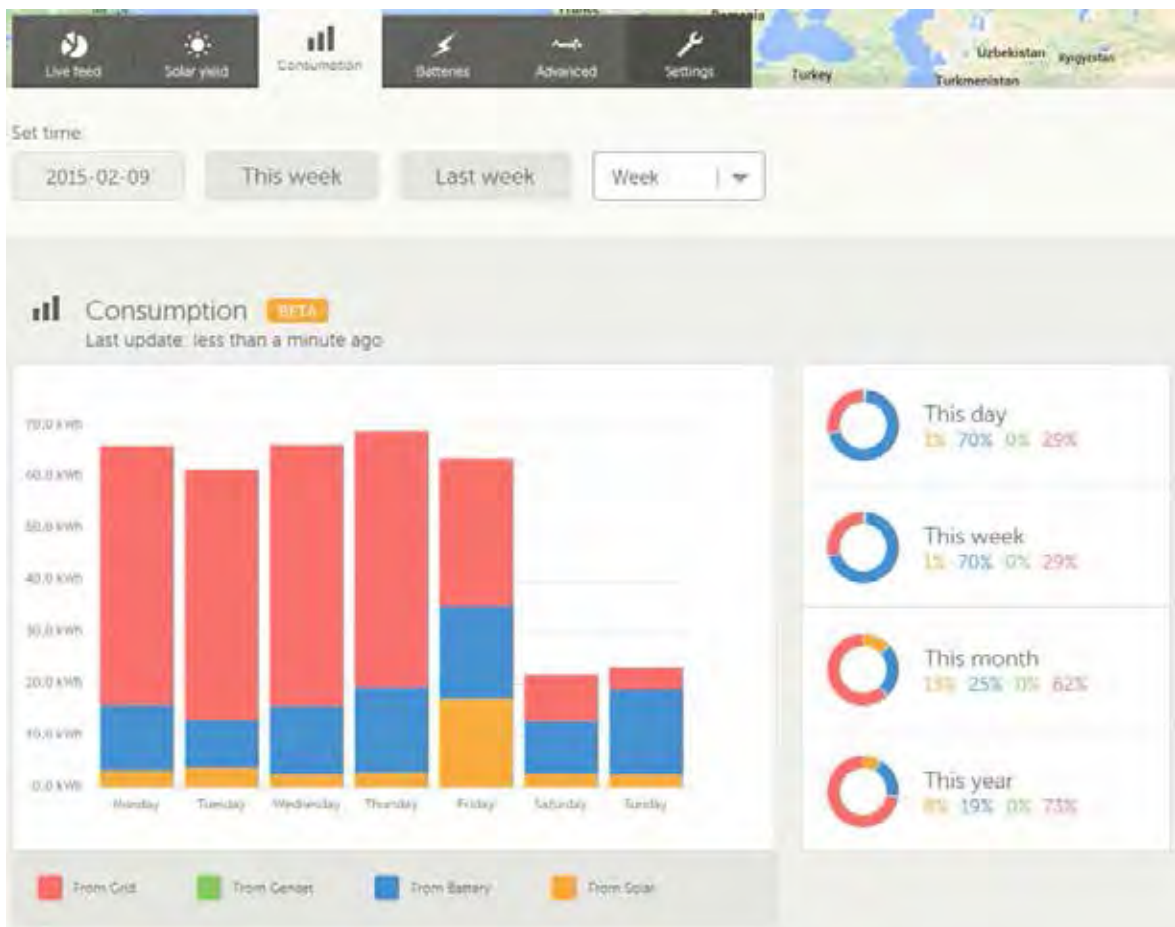

**VRM Portal – Live feed**

**VRM Portal – Consumption**

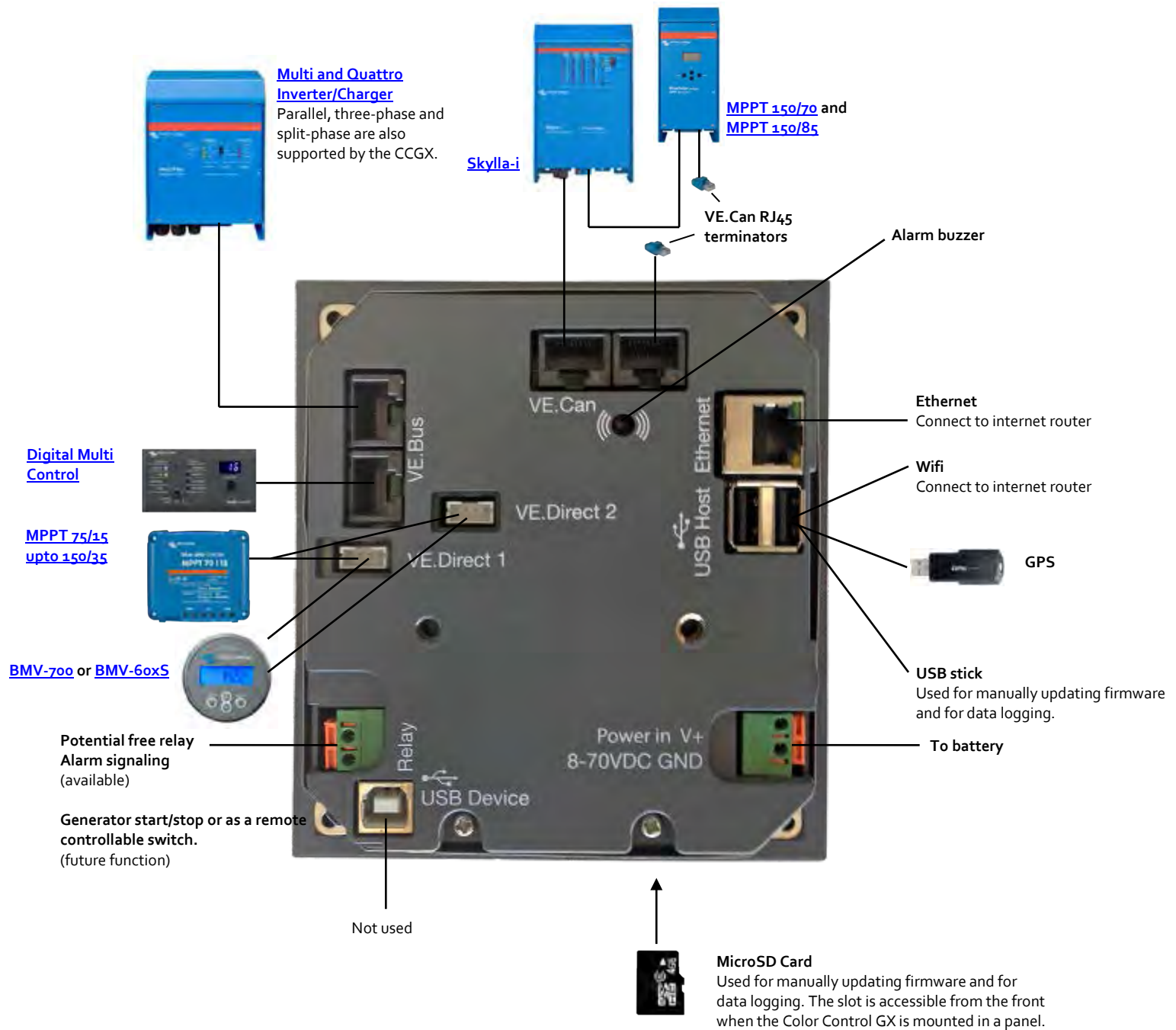
## Color Control GX schematic diagram





## BMV 700 series: Precision battery monitoring



**BMV 700**



**BMV bezel square**



**BMV shunt 500A/50mV**  
With quick connect pcb



**BMV 702 Black**



**BMV 700H**

### Battery 'fuel gauge', time-to-go indicator, and much more

The remaining battery capacity depends on the ampere-hours consumed, discharge current, temperature and the age of the battery. Complex software algorithms are needed to take all these variables into account.

Next to the basic display options, such as voltage, current and ampere-hours consumed, the BMV-700 series also displays state of charge, time to go, and power consumption in Watts.

The BMV-702 features an additional input which can be programmed to measure the voltage (of a second battery), temperature or midpoint voltage (see below).

### Easy to install

All electrical connections are to the quick connect PCB on the current shunt. The shunt connects to the monitor with a standard RJ12 telephone cable. Included: RJ 12 cable (10 m) and battery cable with fuse (2 m); no other components needed.

Also included are a separate front bezel for a square or round display appearance; a securing ring for the rear mounting and screws for the front mounting.

### Easy to program

A quick install menu and a detailed setup menu with scrolling texts assists the user when going through the various settings. Please consult the manual for details.

### New: midpoint voltage monitoring (BMV-702 only)

This feature which is often used in industry to monitor large and expensive battery banks, is now for the first time made available at a low cost, to monitor any battery bank.

A battery bank consists of a string of series connected cells. The midpoint voltage is the voltage halfway along the string. Ideally, the midpoint voltage would be exactly half of the total voltage. In practice, however, deviations will be seen, dependent on many factors such as a different state of charge for new batteries or cells, different temperatures, internal leakage currents, capacities and much more.

Large or increasing deviation of the midpoint voltage, points to improper battery care or a failed battery or cell. Corrective action following a midpoint voltage alarm can prevent severe damage to an expensive battery. Please consult the BMV manual for more information.

### Standard features

- Battery voltage, current, power, ampere-hours consumed and state of charge
- Time to go at the current rate of discharge
- Programmable visual and audible alarm
- Programmable relay, to turn off non critical loads or to run a generator when needed
- 500 Amp quick connect shunt and connection kit
- Shunt selection capability up to 10.000 Amps
- VE.Direct communication port
- Stores a wide range of historical events, which can be used to evaluate usage patterns and battery health
- Wide input voltage range: 9,5 – 95 V
- High current measurement resolution: 10 mA (0,01 A)
- Low current consumption: 2,9 Ah per month (4 mA) @12 V and 2,2 Ah per month (3 mA) @ 24 V

### BMV-702 additional features

Additional input to measure voltage (of a second battery), temperature or midpoint voltage, and corresponding alarm and relay settings.

### BMV 700HS: 60 to 385VDC voltage range

No prescaler needed. Note: suitable for systems with grounded minus only (battery monitor is not isolated from shunt).

### Other battery monitoring options

- VE.Net Battery Controller
- High voltage VE.Net Battery Controller: 70 to 350 VDC
- Lynx Shunt VE.Net
- Lynx Shunt VE.Can

### More about midpoint voltage

One bad cell or one bad battery can destroy a large, expensive battery bank. When batteries are connected in series, a timely warning can be generated by measuring the midpoint voltage. Please see the BMV manual, section 5.2, for more information.

We recommend our [Battery Balancer](#) (BMS012201000) to maximize service life or series-connected batteries.

Battery monitor	BMV 700	BMV 702 BMV 702 BLACK	BMV 700HS
Supply voltage range	6,5 - 95 VDC	6,5 - 95 VDC	60 - 385 VDC
Current draw, back light off	< 4 mA	< 4 mA	< 4 mA
Input voltage range, auxiliary battery	n. a.	6,5 - 95 VDC	n. a.
Battery capacity (Ah)	20 - 9999 Ah		
Operating temperature range	-20 +50°C (0 - 120°F)		
Measures voltage of second battery, or temperature, or midpoint	No	Yes	No
Temperature measurement range	-20 +50°C		n. a.
VE.Direct communication port	Yes	Yes	Yes
Relay	60 V / 1 A normally open (function can be inverted)		
RESOLUTION & ACCURACY (with a 500 A shunt)			
Current	± 0,01 A		
Voltage	± 0,01 V		
Amp hours	± 0,1 Ah		
State of charge (0 - 100%)	± 0,1%		
Time to go	± 1 min		
Temperature (0 - 50°C or 30 - 120°F)	n. a.	± 1°C/°F	n. a.
Accuracy of current measurement	± 0,4%		
Accuracy of voltage measurement	± 0,3%		
INSTALLATION & DIMENSIONS			
Installation	Flush mount		
Front	63 mm diameter		
Front bezel	69 x 69 mm (2.7 x 2.7 inch)		
Body diameter	52 mm (2.0 inch)		
Body depth	31 mm (1.2 inch)		
STANDARDS			
Safety	EN 60335-1		
Emission / Immunity	EN 55014-1 / EN 55014-2		
Automotive	ECE R10-4 / EN 50498		
ACCESSORIES			
Shunt (included)	500 A / 50 mV		
Cables (included)	10 meter 6 core UTP with RJ12 connectors, and cable with fuse for '+' connection		
Temperature sensor	Optional (ASS000100000)		



**Victron Global Remote**

The Global Remote is a modem which sends alarms, warnings and system status reports to cellular phones via text messages (SMS). It can also log data from Victron Battery Monitors, MultiPlus units, Quattros and Inverters to a website through a GPRS connection to the [VRM Portal](#). Access to this website is free of charge. VE.Direct to Global remote Interface cable needed (ASS030534000).



**1000A/50mV and 2000A/50mV shunt**

For ease of use with the BMV series: the quick connect PCB on the standard 500A/50mV shunt can also be mounted on these shunts.



**Interface cables**

- VE.Direct cables to connect a BMV 70x to the Color Control (ASS030530000)
- VE.Direct to USB interface (ASS030530000) to connect several BMV 70x to the Color Control or to a computer.
- VE.Direct to Global remote interface to connect a BMV 70x to a Global Remote. (ASS030534000)

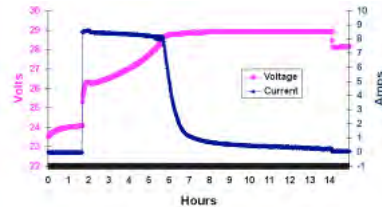

The PC application software **BMV-Reader** will show all current readings on a computer, including history data. It can also log the data to a CSV formatted file. It is available for free, and can be downloaded from our website at the [Support and downloads section](#). Connect the BMV to the computer with the VE.Direct to USB interface, ASS030530000.



**Color Control**

The powerful Linux computer, hidden behind the color display and buttons, collects data from all Victron equipment and shows it on the display. Besides communicating with Victron equipment, the Color Control communicates through CAN bus (NMEA2000), Ethernet and USB. Data can be stored and analyzed on the VRM Portal



A maximum of four BMVs can be connected directly to the Color Control. Even more BMVs can be connected to a USB Hub for central monitoring.



**Battery Balancer (BMS012201000)**

The Battery Balancer equalizes the state of charge of two series connected 12 V batteries, or of several parallel strings of series connected batteries.

When the charge voltage of a 24 V battery system increases to more than 27 V, the Battery Balancer will turn on and compare the voltage over the two series connected batteries. The Battery Balancer will draw a current of up to 1 A from the battery (or parallel connected batteries) with the highest voltage. The resulting charge current differential will ensure that all batteries will converge to the same state of charge.

If needed, several balancers can be paralleled.

A 48 V battery bank can be balanced with three Battery Balancers.



With the VE.Direct to Bluetooth low energy (BLE) dongle real time data and alarms can be displayed on Apple and Android smartphones, tablets and other devices.













## BlueSolar monocrystalline panels

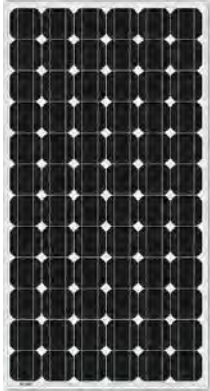

- Low voltage-temperature coefficient enhances high-temperature operation.
- Exceptional low-light performance and high sensitivity to light across the entire solar spectrum.
- 25-year limited warranty on power output and performance.
- 5-year limited warranty on materials and workmanship.
- Sealed, waterproof, multi-functional junction box gives high level of safety.
- High performance bypass diodes minimize the power drop caused by shade.
- Advanced EVA (Ethylene Vinyl Acetate) encapsulation system with triple-layer back sheet meets the most stringent safety requirements for high-voltage operation.
- A sturdy, anodized aluminum frame allows modules to be easily roof-mounted with a variety of standard mounting systems.
- Highest quality, high-transmission tempered glass provides enhanced stiffness and impact resistance.
- High power models with pre wired quick-connect system with MC4 (PV-ST01) connectors.

### BlueSolar Monocrystalline 280W



MC4 connectors

Article number	Description	Weight	Electrical data under STC <sup>(1)</sup>				
			Nominal Power	Max-Power Voltage	Max-Power Current	Open-Circuit	Short-Circuit
			P <sub>MPP</sub>	V <sub>MPP</sub>	I <sub>MPP</sub>	V <sub>oc</sub>	I <sub>sc</sub>
		Kg	W	V	A	V	A
SPM030301200	30W-12V Mono 430×545×25mm series	2.5	30	18	1.67	22.5	2
SPM030501200	50W-12V Mono 630×545×25mm series	4	50	18	2.78	22.2	3.16
SPM030801200	80W-12V Mono 1195×545×35mm series	8	80	18	4.45	22.3	4.96
SPM031001200	10 W-12V Mono 1195×545×35mm series	8	100	18	5.56	22.4	6.53
SPM031301200	130W-12V Mono 1480×673×35mm series	12	130	18	7.23	22.4	8.49
SPM031902400	190W-24V Mono 1580×808×35mm series	15	190	36	5.44	43.2	5.98
SPM033002400	300W-24V Mono 1956×992×45mm series	24	300	36	8.06	45.5	8.56
Module	SPM 030301200	SPM 030501200	SPM 030801200	SPM 031001200	SPM 031301200	SPM 031902400	SPM 033002400
Nominal Power (±3% tolerance)	30 W	50 W	80 W	100 W	130 W	190 W	300 W
Cell type	Monocrystalline						
Number of cells in series	36					72	
Maximum system voltage (V)	1000V						
Temperature coefficient of P <sub>MPP</sub> (%)	-0.48/°C	-0.48/°C	-0.48/°C	-0.48/°C	-0.48/°C	-0.48/°C	-0.48/°C
Temperature coefficient of V <sub>oc</sub> (%)	-0.34/°C	-0.34/°C	-0.34/°C	-0.34/°C	-0.34/°C	-0.34/°C	-0.34/°C
Temperature coefficient of I <sub>sc</sub> (%)	+0.037/°C	+0.037/°C	+0.037/°C	+0.037/°C	+0.05/°C	+0.037/°C	+0.037/°C
Temperature Range	-40°C to +85°C						
Surface Maximum Load Capacity	200 kg/m <sup>2</sup>						
Allowable Hail Load	23 m/s, 7.53 g						
Junction Box Type	PV-LH0801		PV-LH0808			PV-JB002	
Length of Cables / Connector Type	No cable	No cable	900 mm MC4				
Output tolerance	+/-3%						
Frame	Aluminium						
Product warranty	5 years						
Warranty on electrical performance	10 years 90% + 25 years 80% of power output						
Smallest packaging unit	1 panel						
Quantity per pallet	100		40		20		18

1) STC (Standard Test Conditions): 1000 W/m<sup>2</sup>, 25°C, AM (Air Mass) 1.5



BlueSolar Polycrystalline 140W

- Low voltage-temperature coefficient enhances high-temperature operation.
- Exceptional low-light performance and high sensitivity to light across the entire solar spectrum.
- 25-year limited warranty on power output and performance.
- 5-year limited warranty on materials and workmanship.
- Sealed, waterproof, multi-functional junction box gives high level of safety.
- High performance bypass diodes minimize the power drop caused by shade.
- Advanced EVA (Ethylene Vinyl Acetate) encapsulation system with triple-layer back sheet meets the most stringent safety requirements for high-voltage operation.
- A sturdy, anodized aluminum frame allows modules to be easily roof-mounted with a variety of standard mounting systems.
- Highest quality, high-transmission tempered glass provides enhanced stiffness and impact resistance.
- High power models with pre wired quick-connect system with MC4 (PV-ST01) connectors.



MC4 connectors

Article number	Description	Net weight	Electrical data under STC <sup>(a)</sup>							
			Nominal Power	Max-Power Voltage	Max-Power Current	Open-Circuit Voltage	Short-Circuit Current			
			PMPP	VMPP	IMPP	Voc	Isc			
		Kg	W	V	A	V	A			
SPP030201200	20 W-12 V Poly 480x350x25 mm series 3a	2.2	20	18	1.11	22.5	1.23			
SPP030301200	30 W-12 V Poly 410x670x25 mm series 3a	3.7	30	18	1.67	22.5	1.85			
SPP020401200	40 W-12 V Poly 670x475x25 mm series 2a	4.2	40	18	2.22	22.5	1.85			
SPP030501200	50 W-12 V Poly 540x670x25 mm series 3a	4.3	50	18	2.78	22.2	3.09			
SPP020751200	75 W-12 V Poly 780x670x25 mm series 2a	6.6	75	18	4.17	22.2	4.64			
SPP030801200	80 W-12 V Poly 840x670x35 mm series 3a	6.8	80	18	4.44	21.6	5.06			
SPP031001200	100 W-12 V Poly 1000x670x35 mm series 3a	8.9	100	18	5.56	21.6	6.32			
SPP031401200	140 W-12 V Poly 1480x673x35 mm series 3a	12	140	20	7.78	21.6	8.85			
SPP032502400	250 W-20 V Poly 1650x992x40 mm series 3a	18	250	30	8.33	36.01	9.40			
SPP032902400	290 W-24 V Poly 1956x992x45 mm series 3a	24	290	36	8.06	44.10	8.56			
Module	SPP 030201200	SPP 030301200	SPP 020401200	SPP 030501200	SPP 020751200	SPP 030801200	SPP 031001200	SPP 031401200	SPP 032502400	SPP 032902400
Nominal Power (± 3% tolerance)	20 W	30 W	40 W	50 W	75 W	80 W	100 W	140 W	250 W	290 W
Cell type	Polycrystalline									
Number of cells in series	36							40	60	72
Maximum system voltage (V)	1000V									
Temperature coefficient of PMPP (%)	-0.47/°C	-0.48/°C			-0.48/°C		-0.48/°C		-0.47/°C	
Temperature coefficient of Voc (%)	-0.34/°C	-0.34/°C			-0.34/°C		-0.35/°C		-0.34/°C	
Temperature coefficient of Isc (%)	+0.045/°C	+0.037/°C			+0.037/°C		+0.037/°C		+0.045/°C	
Temperature Range	-40°C to +85°C									
Surface Maximum Load Capacity	200 kg/m <sup>2</sup>									
Allowable Hail Load	23 m/s, 7.53 g									
Junction Box Type	PV-LH0801				PV-JH02	PV-LH0808			PV-JB002	
Length of Cable / connector	No cable	No cable	No cable	No cable	900 mm / MC4					
Output tolerance	+/-3%									
Frame	Aluminium									
Product warranty	5 years									
Warranty on electrical performance	10 years 90% + 25 years 80% of power output									
Smallest packaging unit	1 panel									
Quantity per pallet	150	100			20			19	18	

<sup>1)</sup> STC (Standard Test Conditions): 1000 W/m<sup>2</sup>, 25°C, AM (Air Mass) 1.5



Solar Charge Controller  
MPPT 75/15

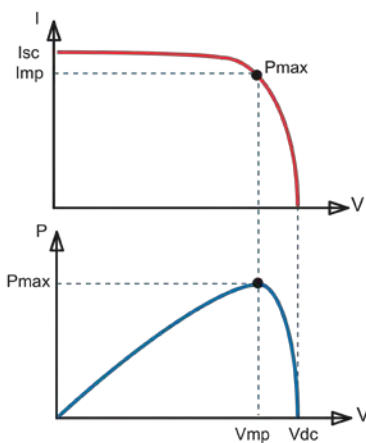

Maximum Power Point Tracking

Upper curve:

Output current (I) of a solar panel as function of output voltage (V). The Maximum Power Point (MPP) is the point Pmax along the curve where the product I x V reaches its peak.

Lower curve:

Output power P = I x V as function of output voltage. When using a PWM (not MPPT) controller the output voltage of the solar panel will be nearly equal to the voltage of the battery, and will be lower than Vmp.

Ultra-fast Maximum Power Point Tracking (MPPT)

Especially in case of a cloudy sky, when light intensity is changing continuously, an ultra-fast MPPT controller will improve energy harvest by up to 30% compared to PWM charge controllers and by up to 10% compared to slower MPPT controllers.

Load output

Over-discharge of the battery can be prevented by connecting all loads to the load output. The load output will disconnect the load when the battery has been discharged to a pre-set voltage.

Alternatively, an intelligent battery management algorithm can be chosen: see Battery Life.

The load output is short circuit proof.

Some loads (especially inverters) can best be connected directly to the battery, and the inverter remote control connected to the load output. A special interface cable may be needed, please see the manual.

Battery Life: intelligent battery management

When a solar charge controller is not able to recharge the battery to its full capacity within one day, the result is often that the battery will continually be cycled between a 'partially charged' state and the 'end of discharge' state. This mode of operation (no regular full recharge) will destroy a lead-acid battery within weeks or months.

The Battery Life algorithm will monitor the state of charge of the battery and, if needed, day by day slightly increase the load disconnect level (i.e. disconnect the load earlier) until the harvested solar energy is sufficient to recharge the battery to nearly the full 100%. From that point onwards the load disconnect level will be modulated so that a nearly 100% recharge is achieved about once every week.

Programmable battery charge algorithm

See the software section on our website for details

Day/night timing and light dimming option

See the software section on our website for details

Real-time data display options

- Apple and Android smartphones, tablets and other devices: see the VE.Direct to Bluetooth low energy dongle
- ColorControl panel



BlueSolar Charge Controller	MPPT 75/10	MPPT 75/15	MPPT 100/15
Battery voltage	12/24 V Auto Select		
Rated charge current	10 A	15 A	15 A
Maximum PV power, 12V 1a,b)	135 W	200 W	200 W
Maximum PV power, 24V 1a,b)	270 W	400 W	400 W
Automatic load disconnect	Yes, maximum load 15 A		
Maximum PV open circuit voltage	75 V		100 V
Peak efficiency	98%		
Self-consumption	10 mA		
Charge voltage 'absorption'	14,4 V / 28,8 V (adjustable)		
Charge voltage 'float'	13,8 V / 27,6 V (adjustable)		
Charge algorithm	multi-stage adaptive		
Temperature compensation	-16 mV / °C resp. -32 mV / °C		
Continuous/peak load current	15A / 50A		
Low voltage load disconnect	11,1 V / 22,2 V or 11,8 V / 23,6 V or Battery Life algorithm		
Low voltage load reconnect	13,1 V / 26,2 V or 14 V / 28 V or Battery Life algorithm		
Protection	Battery reverse polarity (fuse) Output short circuit / Over temperature		
Operating temperature	-30 to +60°C (full rated output up to 40°C)		
Humidity	95%, non-condensing		
Data communication port	VE.Direct See the data communication white paper on our website		
<b>ENCLOSURE</b>			
Colour	Blue (RAL 5012)		
Power terminals	6 mm <sup>2</sup> / AWG10		
Protection category	IP22 (connection area)		
Weight	0,5 kg		
Dimensions (h x w x d)	100 x 113 x 40 mm		
<b>STANDARDS</b>			
Safety	EN/IEC 62109		

1a) If more PV power is connected, the controller will limit input power to the stated maximum.  
1b) PV voltage must exceed Vbat + 5 V for the controller to start.  
Thereafter minimum PV voltage is Vbat + 1 V





Solar Charge Controller  
MPPT 100/30

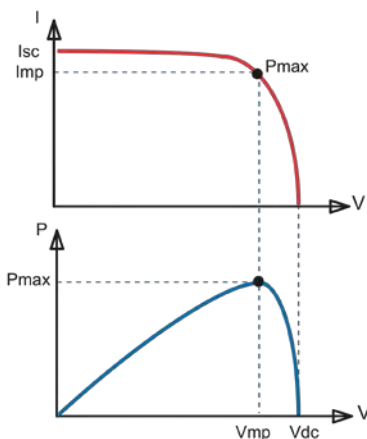

### Maximum Power Point Tracking

#### Upper curve:

Output current (I) of a solar panel as function of output voltage (V). The Maximum Power Point (MPP) is the point Pmax along the curve where the product  $I \times V$  reaches its peak.

#### Lower curve:

Output power  $P = I \times V$  as function of output voltage. When using a PWM (not MPPT) controller the output voltage of the solar panel will be nearly equal to the voltage of the battery, and will be lower than Vmp.

### Ultra-fast Maximum Power Point Tracking (MPPT)

Especially in case of a cloudy sky, when light intensity is changing continuously, an ultra-fast MPPT controller will improve energy harvest by up to 30% compared to PWM charge controllers and by up to 10% compared to slower MPPT controllers.

### Advanced Maximum Power Point Detection in case of partial shading conditions

If partial shading occurs, two or more maximum power points may be present on the power-voltage curve.

Conventional MPPT's tend to lock to a local MPP, which may not be the optimum MPP.

The innovative BlueSolar algorithm will always maximize energy harvest by locking to the optimum MPP.

### Outstanding conversion efficiency

No cooling fan. Maximum efficiency exceeds 98%. Full output current up to 40°C (104°F).

### Flexible charge algorithm

Fully programmable charge algorithm (see the software page on our website), and eight pre-programmed algorithms, selectable with a rotary switch (see manual for details).

### Extensive electronic protection

Over-temperature protection and power derating when temperature is high.

PV short circuit and PV reverse polarity protection.

PV reverse current protection.

### Internal temperature sensor

Compensates absorption and float charge voltage for temperature.

### Real-time data display options

- Apple and Android smartphones, tablets and other devices: see the VE.Direct to Bluetooth low energy dongle
- ColorControl panel



BlueSolar Charge Controller	MPPT 100/30
Battery voltage	12/24 V Auto Select
Maximum output current	30 A
Maximum PV power, 12V 1a,b)	440 W (MPPT range 15 V to 80 V)
Maximum PV power, 24V 1a,b)	880 W (MPPT range 30 V to 80 V)
Maximum PV open circuit voltage	100 V
Maximum efficiency	98%
Self-consumption	10 mA
Charge voltage 'absorption'	Default setting: 14,4 V / 28,8 V (adjustable)
Charge voltage 'float'	Default setting: 13,8 V / 27,6 V (adjustable)
Charge algorithm	multi-stage adaptive
Temperature compensation	-16 mV / °C resp. -32 mV / °C
Protection	Battery reverse polarity (fuse, not user accessible) Output short circuit Over temperature
Operating temperature	-30 to +60°C (full rated output up to 40°C)
Humidity	95 %, non-condensing
Data communication port	VE.Direct
	See the data communication white paper on our website
ENCLOSURE	
Colour	Blue (RAL 5012)
Power terminals	13 mm <sup>2</sup> / AWG6
Protection category	IP43 (electronic components), IP22 (connection area)
Weight	1,25 kg
Dimensions (h x w x d)	130 x 186 x 70 mm
STANDARDS	
Safety	EN/IEC 62109
1a) If more PV power is connected, the controller will limit input power to 440W resp. 880 W	
1b) PV voltage must exceed Vbat + 5 V for the controller to start.	
Thereafter minimum PV voltage is Vbat + 1 V	



**Solar Charge Controller  
MPPT 100/50**

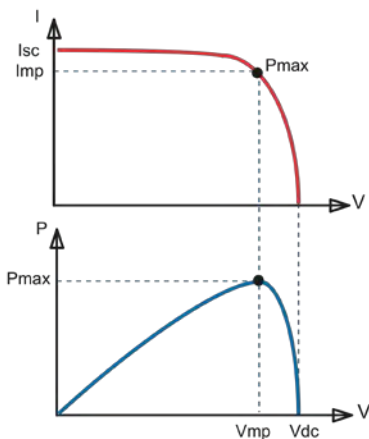

### Maximum Power Point Tracking

#### Upper curve:

Output current (I) of a solar panel as function of output voltage (V). The Maximum Power Point (MPP) is the point Pmax along the curve where the product  $I \times V$  reaches its peak.

#### Lower curve:

Output power  $P = I \times V$  as function of output voltage. When using a PWM (not MPPT) controller the output voltage of the solar panel will be nearly equal to the voltage of the battery, and will be lower than Vmp.

### Ultra-fast Maximum Power Point Tracking (MPPT)

Especially in case of a cloudy sky, when light intensity is changing continuously, an ultra-fast MPPT controller will improve energy harvest by up to 30% compared to PWM charge controllers and by up to 10% compared to slower MPPT controllers.

### Advanced Maximum Power Point Detection in case of partial shading conditions

If partial shading occurs, two or more maximum power points may be present on the power-voltage curve.

Conventional MPPTs tend to lock to a local MPP, which may not be the optimum MPP.

The innovative BlueSolar algorithm will always maximize energy harvest by locking to the optimum MPP.

### Outstanding conversion efficiency

No cooling fan. Maximum efficiency exceeds 98%. Full output current up to 40°C (104°F).

### Flexible charge algorithm

Fully programmable charge algorithm (see the software page on our website), and eight pre-programmed algorithms, selectable with a rotary switch (see manual for details).

### Extensive electronic protection

Over-temperature protection and power derating when temperature is high.

PV short circuit and PV reverse polarity protection.

PV reverse current protection.

### Internal temperature sensor

Compensates absorption and float charge voltage for temperature.

### Real-time data display options

- Apple and Android smartphones, tablets and other devices: see the VE.Direct to Bluetooth low energy dongle
- ColorControl panel



BlueSolar Charge Controller	MPPT 100/50
Battery voltage	12/24 V Auto Select
Rated charge current	50 A
Maximum PV power, 12 V 1a,b)	700 W (MPPT range 15 V to 70 V resp. 95 V)
Maximum PV power, 24 V 1a,b)	1400 W (MPPT range 30 V to 70 V resp. 95 V)
Maximum PV open circuit voltage	100 V
Maximum efficiency	9 %
Self-consumption	10 mA
Charge voltage 'absorption'	Default setting: 14,4 V / 28,8 V (adjustable)
Charge voltage 'float'	Default setting: 13,8 V / 27,6 V (adjustable)
Charge algorithm	multi-stage adaptive
Temperature compensation	-16 mV / °C resp. -32 mV / °C
Protection	Battery reverse polarity (fuse, not user accessible) PV reverse polarity Output short circuit Over temperature
Operating temperature	-30 to +60°C (full rated output up to 40°C)
Humidity	95%, non-condensing
Data communication port	VE.Direct See the data communication white paper on our website
ENCLOSURE	
Colour	Blue (RAL 5012)
Power terminals	13 mm <sup>2</sup> / AWG6
Protection category	IP43 (electronic components), IP22 (connection area)
Weight	1,25 kg
Dimensions (h x w x d)	130 x 186 x 70 mm
STANDARDS	
Safety	EN/IEC 62109
1a) If more PV power is connected, the controller will limit input power to 700W resp. 1400W	
1b) PV voltage must exceed Vbat + 5 V for the controller to start. Thereafter minimum PV voltage is Vbat + 1 V	



Solar Charge Controller  
MPPT 150/35

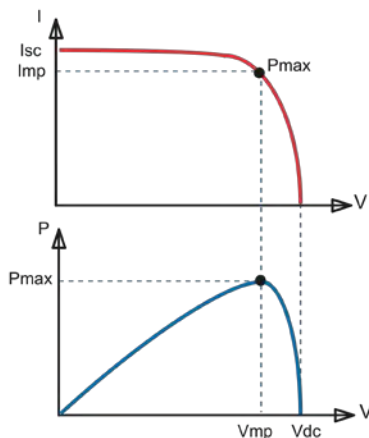

### Maximum Power Point Tracking

#### Upper curve:

Output current (I) of a solar panel as function of output voltage (V).

The Maximum Power Point (MPP) is the point Pmax along the curve where the product  $I \times V$  reaches its peak.

#### Lower curve:

Output power  $P = I \times V$  as function of output voltage.

When using a PWM (not MPPT) controller the output voltage of the solar panel will be nearly equal to the voltage of the battery, and will be lower than  $V_{mp}$ .

### Ultra-fast Maximum Power Point Tracking (MPPT)

Especially in case of a cloudy sky, when light intensity is changing continuously, an ultra-fast MPPT controller will improve energy harvest by up to 30% compared to PWM charge controllers and by up to 10% compared to slower MPPT controllers.

### Advanced Maximum Power Point Detection in case of partial shading conditions

If partial shading occurs, two or more maximum power points may be present on the power-voltage curve.

Conventional MPPTs tend to lock to a local MPP, which may not be the optimum MPP.

The innovative BlueSolar algorithm will always maximize energy harvest by locking to the optimum MPP.

### Outstanding conversion efficiency

No cooling fan. Maximum efficiency exceeds 98%. Full output current up to 40°C (104°F).

### Flexible charge algorithm

Fully programmable charge algorithm (see the software page on our website), and eight preprogrammed algorithms, selectable with a rotary switch (see manual for details).

### Extensive electronic protection

Over-temperature protection and power derating when temperature is high.

PV short circuit and PV reverse polarity protection.

PV reverse current protection.

### Internal temperature sensor

Compensates absorption and float charge voltage for temperature.

### Real-time data display options

- Apple and Android smartphones, tablets and other devices:

see the VE.Direct to Bluetooth low energy dongle

- ColorControl panel



BlueSolar Charge Controller	MPPT 150/35
Battery voltage	12 / 24 / 48 V Auto Select (software tool needed to select 36 V)
Rated charge current	35 A
Maximum PV power 1a,b)	12 V: 500 W / 24 V: 1000 W / 36 V: 1500 W / 48 V: 2000 W
Maximum PV open circuit voltage	150 V absolute maximum coldest conditions 145 V start-up and operating maximum
Maximum efficiency	98%
Self-consumption	0,001 mA (1 $\mu$ A)
Charge voltage 'absorption'	Default setting: 14,4 / 28,8 / 43,2 / 57,6 V (adjustable)
Charge voltage 'float'	Default setting: 13,8 / 27,6 / 41,4 / 55,2 V (adjustable)
Charge algorithm	multi-stage adaptive
Temperature compensation	-16 mV / °C resp. -32 mV / °C
Protection	Battery reverse polarity (fuse, not user accessible) PV reverse polarity Output short circuit Over-temperature
Operating temperature	-30 to +60°C (full rated output up to 40°C)
Humidity	95%, non-condensing
Data communication port	VE.Direct See the data communication white paper on our website
<b>ENCLOSURE</b>	
Colour	Blue (RAL 5012)
Power terminals	13 mm <sup>2</sup> / AWG6
Protection category	IP43 (electronic components), IP22 (connection area)
Weight	1,25 kg
Dimensions (h x w x d)	130 x 186 x 70 mm
<b>STANDARDS</b>	
Safety	EN/IEC 62109
1a) If more PV power is connected, the controller will limit input power to the stated maximum	
1b) PV voltage must exceed $V_{bat} + 5$ V for the controller to start. Thereafter minimum PV voltage is $V_{bat} + 1$ V	





Solar charge controller  
MPPT 150/70-Tr



Solar charge controller  
MPPT 150/70-MC4

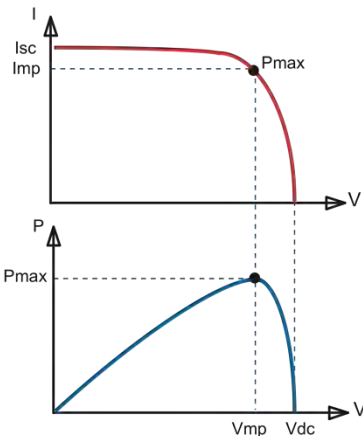

Maximum Power Point Tracking

**Upper curve:**

Output current (I) of a solar panel as function of output voltage (V). The maximum power point (MPP) is the point Pmax along the curve where the product I x V reaches its peak.

**Lower curve:**

Output power  $P = I \times V$  as function of output voltage. When using a PWM (not MPPT) controller the output voltage of the solar panel will be nearly equal to the voltage of the battery, and will be lower than Vmp.

**Ultra-fast Maximum Power Point Tracking (MPPT)**

Especially in case of a clouded sky, when light intensity is changing continuously, an ultra-fast MPPT controller will improve energy harvest by up to 30% compared to PWM charge controllers and by up to 10% compared to slower MPPT controllers.

**Advanced Maximum Power Point Detection in case of partial shading conditions**

If partial shading occurs, two or more maximum power points may be present on the power-voltage curve.

Conventional MPPT's tend to lock to a local MPP, which may not be the optimum MPP. The innovative BlueSolar algorithm will always maximize energy harvest by locking to the optimum MPP.

**Outstanding conversion efficiency**

No cooling fan. Maximum efficiency exceeds 98%.

**Flexible charge algorithm**

Fully programmable charge algorithm (see the software page on our website), and eight preprogrammed algorithms, selectable with a rotary switch (see manual for details).

**Extensive electronic protection**

Over-temperature protection and power derating when temperature is high. PV short circuit and PV reverse polarity protection. PV reverse current protection.

**Internal temperature sensor**

Compensates absorption and float charge voltage for temperature.

**Real-time data display options**

- Apple and Android smartphones, tablets and other devices: see the VE.Direct to Bluetooth Smart dongle
- ColorControl panel

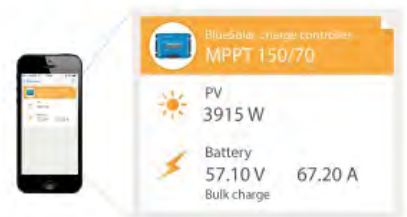

BlueSolar charge controller	MPPT 150/45	MPPT 150/60	MPPT 150/70
Battery voltage	12 / 24 / 48 V Auto Select (software tool needed to select 36 V)		
Rated charge current	45 A	60 A	70 A
Maximum PV power, 12V 1a,b)	650 W	860 W	1000 W
Maximum PV power, 24V 1a,b)	1300 W	1720 W	2000 W
Maximum PV power, 48V 1a,b)	2600 W	3440 W	4000 W
Maximum PV open circuit voltage	150V absolute maximum coldest conditions 145V start-up and operating maximum		
Maximum efficiency	98 %		
Self-consumption	10 mA		
Charge voltage 'absorption'	Default setting: 14,4 / 28,8 / 43,2 / 57,6 V (adjustable)		
Charge voltage 'float'	Default setting: 13,8 / 27,6 / 41,4 / 55,2 V (adjustable)		
Charge algorithm	multi-stage adaptive		
Temperature compensation	-16 mV / °C resp. -32 mV / °C		
Protection	Battery reverse polarity (fuse, not user accessible) PV reverse polarity / Output short circuit / Over temperature		
Operating temperature	-30 to +60°C (full rated output up to 40°C)		
Humidity	95 %, non-condensing		
Data communication port and remote on-off	VE.Direct (see the data communication white paper on our website)		
Synchronized parallel operation	Not possible		
<b>ENCLOSURE</b>			
Colour	Blue (RAL 5012)		
PV terminals 2)	35 mm <sup>2</sup> / AWG2 (Tr models), or Dual MC4 connectors (MC4 models)		
Battery terminals	35 mm <sup>2</sup> / AWG2		
Protection category	IP43 (electronic components), IP22 (connection area)		
Weight	3 kg		
Dimensions (h x w x d)	200 x 250 x 95 mm		
<b>STANDARDS</b>			
Safety	EN/IEC 62109		
1a) If more PV power is connected, the controller will limit input power to the stated maximum.			
1b) PV voltage must exceed Vbat + 5V for the controller to start. Thereafter minimum PV voltage is Vbat + 1V			
2) MC4 models: several splitter pairs will be needed to parallel the strings of solar panels			

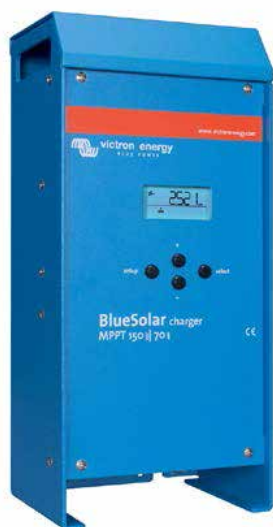

Solar Charge Controllers  
MPPT 150/70 and 150/85

#### PV voltage up to 150 V

The BlueSolar MPPT 150/70 and 150/85 charge controllers will charge a lower nominal-voltage battery from a higher nominal voltage PV array.

The controller will automatically adjust to a 12, 24, 36, or 48 V nominal battery voltage.

#### Ultra-fast Maximum Power Point Tracking (MPPT)

Especially in case of a cloudy sky, when light intensity is changing continuously, an ultra-fast MPPT controller will improve energy harvest by up to 30% compared to PWM charge controllers and by up to 10% compared to slower MPPT controllers.

#### Advanced Maximum Power Point Detection in case of partial shading conditions

If partial shading occurs, two or more maximum power points may be present on the power-voltage curve. Conventional MPPT's tend to lock to a local MPP, which may not be the optimum MPP.

The innovative BlueSolar algorithm will always maximize energy harvest by locking to the optimum MPP.

#### Outstanding conversion efficiency

Maximum efficiency exceeds 98%. Full output current up to 40°C (104°F).

#### Flexible charge algorithm

Several preconfigured algorithms. One user programmable algorithm.

Manual or automatic equalisation.

Battery temperature sensor. Battery voltage sense option.

#### Programmable auxiliary relay

For alarm or generator start purposes

#### Extensive electronic protection

Over-temperature protection and power derating when temperature is high.

PV short circuit and PV reverse polarity protection.

Reverse current protection.

#### CAN bus

To parallel up to 25 units, to connect to a ColorControl panel or to connect to a CAN bus network

BlueSolar Charge Controller	MPPT 150/70	MPPT 150/85
Nominal battery voltage	12 / 24 / 36 / 48 V Auto Select	
Rated charge current	70A @ 40°C (104°F)	85A @ 40°C (104°F)
Maximum solar array input power 1)	12 V: 1000 W / 24 V: 2000 W / 36 V: 3000 W / 48 V: 4000 W	12 V: 1200 W / 24 V: 2400 W / 36 V: 3600 W / 48 V: 4850 W
Maximum PV open circuit voltage	150 V absolute maximum coldest conditions 145 V start-up and operating maximum	
Minimum PV voltage	Battery voltage plus 7 Volt to start	Battery voltage plus 2 Volt operating
Standby power consumption	12 V: 0,55 W / 24 V: 0,75 W / 36 V: 0,90 W / 48 V: 1,00 W	
Efficiency at full load	12 V: 95% / 24 V: 96,5% / 36 V: 97% / 48 V: 97,5%	
Absorption charge	14.4 / 28.8 / 43.2 / 57.6 V	
Float charge	13.7 / 27.4 / 41.1 / 54.8 V	
Equalization charge	15.0 / 30.0 / 45 / 60 V	
Remote battery temperature sensor	Yes	
Default temperature compensation setting	-2,7 mV/°C per 2 V battery cell	
Remote on/off	No	Yes
Programmable relay	DPST AC rating: 240 VAC / 4 A DC rating: 4 A up to 35 VDC, 1 A up to 60 VDC	
Communication port	VE.Can: two paralleled RJ45 connectors, NMEA2000 protocol	
Parallel operation	Yes, through VE.Can. Max 25 units in parallel	
Operating temperature	-40°C to 60°C with output current derating above 40°C	
Cooling	Natural Convection	Low noise fan assisted
Humidity (non condensing)	Max. 95%	
Terminal size	35 mm² / AWG2	
Material & color	Aluminium, blue RAL 5012	
Protection class	IP20	
Weight	4,2 kg	
Dimensions (h x w x d)	350 x 160 x 135 mm	
Mounting	Vertical wall mount	Indoor only
Safety	EN 60335-1	
EMC	EN 61000-6-1, EN 61000-6-3	

1) If more solar power is connected, the controller will limit input power to the stated maximum

## BlueSolar PWM-Light charge controllers



BlueSolar PWM-Light 10 A

### Features

- Load output with low battery voltage disconnect function.
- Lighting control function, one timer only.
- Two digit seven segment display for quick and easy setting of the load output functionality, including timer setting.
- Three stage battery charging (bulk, absorption, float), not programmable.
- Load output protected against over load and short circuit.
- Protected against reverse polarity connection of the solar array and/or battery.

### Day/night timing options

See manual for details

BlueSolar PWM-Light	12/24-5	12/24-10	12/24-20	12/24-30
Battery Voltage	12/24 V with automatic system voltage detection			
Rated charge current	5 A	10 A	20 A	30 A
Automatic load disconnect	Yes			
Maximum solar voltage	28 V / 55 V <sup>(1)</sup>			
Self-consumption	< 10 mA			
Load output	Manual control + low voltage disconnect			
Protection	Battery reverse polarity (fuse)	Output short circuit	Over temperature	
Overload protection	Shut down after 60 s in case of 130% load			
	Shut down after 5 s in case of 160% load			
	Short circuit: immediate shut down			
Grounding	Common positive			
Operating temp. range	-20 to +50°C (full load)			
Humidity (non condensing)	Max 95%			
<b>BATTERY</b>				
Charge voltage 'absorption'	14,2 V / 28,4 V			
Charge voltage 'float'	13,8 V / 27,6 V			
Low voltage load disconnect	11,2 V / 22,4 V			
Low voltage load reconnect	12,6 V / 25,2 V (manual)			
	13,1 V / 26,2 V (automatic)			
<b>ENCLOSURE</b>				
Protection class	IP20			
Terminal size	5 mm <sup>2</sup> / AWG10			
Weight	0,15 kg			0,2 kg
Dimensions (h x w x d)	70 x 133 x 33,5 mm (2.8 x 5.3 x 1.3 inch)			
<b>STANDARDS</b>				
Safety	IEC 62109-1			
EMC	EN 61000-6-1, EN 61000-6-3, ISO 7637-2			
<sup>1)</sup> For 12 V use 36 cell solar panels For 24 V use 72 cell solar panels or 2x 36 cell in series		<sup>2)</sup> The controller switches to the lower float voltage level 2 hours after the absorption voltage has been reached. Whenever the battery voltage becomes lower than 13 V, a new charge cycle is triggered.		



BlueSolar PWM-Pro 10 A



BlueSolar Pro Remote Panel

### Programmable

The BlueSolar PWM-Pro series is ready for use with its default settings.

It also is fully programmable:

- With help of a computer and software (available free of charge from our website)
- With the dedicated BlueSolar Pro Remote Panel (see features below).

### Features

- Lighting control function, fully programmable.
- Three stage battery charging (bulk, absorption, float), fully programmable.
- Integrated battery monitor function (Remote Panel needed to display state of charge).
- Load output with low voltage disconnect and manual control (default setting).
- Optional external temperature sensor.
- Load output protected against over load and short circuit.
- Protected against reverse polarity connection of the solar array and/or battery.

### Day/night timing options

See Remote Panel manual for details

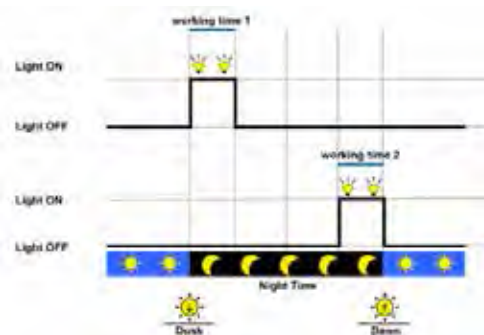

BlueSolar PWM-Pro	12/24-5	12/24-10	12/24-20	12/24-30
Battery Voltage	12/24 V with automatic system voltage detection			
Rated charge current	5 A	10 A	20 A	30 A
Automatic load disconnect	Yes			
Maximum solar voltage	28 V / 55 V (1)			
Self-consumption	< 10 mA			
Load output	Manual control + low voltage disconnect			
Protection	Battery reverse polarity (fuse)	Output short circuit	Over temperature	
Battery temperature sensor	Optional (article SCC940100100)			
Temperature compensation	-30 mV / °C resp. -60 mV / °C (if temperature sensor installed)			
Remote panel	Optional (article SCC900300000)			
Grounding	Common positive			
Operating temp. range	-20 to +50°C			
Humidity (non-condensing)	Max 98%			

### DEFAULT SETTINGS

Absorption charge (2)	14,4 V / 28,8 V			
Float charge (2)	13,8 V / 27,6 V			
Equalization charge (2)	14,6 V / 29,2 V			
Low voltage load disconnect	11,1 V / 22,2 V			
Low voltage load reconnect	12,6 V / 25,2 V			

### ENCLOSURE

	4 mm <sup>2</sup>	4 mm <sup>2</sup>	10 mm <sup>2</sup>	10 mm <sup>2</sup>
Terminal size	4 mm <sup>2</sup>	4 mm <sup>2</sup>	10 mm <sup>2</sup>	10 mm <sup>2</sup>
Protection category	IP30			
Weight	0,13 kg	0,13 kg	0,3 kg	0,5 kg
Dimensions (h x w x d)	138x70x37 mm 5.4x2.7x1.4 inch	138x70x37 mm 5.4x2.7x1.4 inch	160x82x48 mm 6.3x3.2x1.9 inch	200x100x57 mm 7.9x4.0x2.3 inch

### STANDARDS

Safety	IEC 62109-1			
Emission	EN 61000-6-1, EN 61000-6-3, ISO 7637-2			

1) For 12 V use 36 cell Solar panels  
For 24 V use 72 cell Solar panels











## Battery Balancer

### The problem: the service life of an expensive battery bank can be substantially shortened due to state of charge unbalance

One battery with a slightly higher internal leakage current in a 24 V or 48 V bank of several series/parallel connected batteries will cause undercharge of that battery and parallel connected batteries, and overcharge of the series connected batteries. Moreover, when new cells or batteries are connected in series, they should all have the same initial state of charge. Small differences will be ironed out during absorption or equalize charging, but large differences will result in damage due to excessive gassing (caused by overcharging) of the batteries with the higher initial state of charge and sulphation (caused by undercharging) of the batteries with the lower initial state of charge.

### The Solution: battery balancing

The Battery Balancer equalizes the state of charge of two series connected 12 V batteries, or of several parallel strings of series connected batteries.

When the charge voltage of a 24 V battery system increases to more than 27,3 V, the Battery Balancer will turn on and compare the voltage over the two series connected batteries. The Battery Balancer will draw a current of up to 0,7 A from the battery (or parallel connected batteries) with the highest voltage. The resulting charge current differential will ensure that all batteries will converge to the same state of charge.

If needed, several balancers can be paralleled.

A 48 V battery bank can be balanced with three Battery Balancers.

### LED indicators

**Green:** on (battery voltage > 27,3 V)

**Orange:** lower battery leg active (deviation > 0,1 V)

**Orange:** upper battery leg active (deviation > 0,1 V)

**Red:** alarm (deviation > 0,2 V). Remains on until the deviation has reduced to less than 0,14 V, or until system voltage drops to less than 26,6 V.

### Alarm relay

Normally open. Closes when the red LED switches on and opens when the red LED switches off.

### Alarm reset

Two terminals are available to connect a push button. Interconnecting the two terminals resets the relay.

The reset condition will remain active until the alarm is over. Thereafter the relay will close again when a new alarm occurs.

### Even more insight and control with the midpoint monitoring function of the BMV-702 battery monitor

The BMV-702 measures the midpoint of a string of cells or batteries. It displays the deviation from the ideal midpoint in volts or percent. Separate deviation percentages can be set to trigger a visual/audible alarm and to close a potential free relay contact for remote alarm purposes.

Please see the manual of the BMV-702 for more information about battery balancing.

### Learn more about batteries and battery charging

To learn more about batteries and charging batteries, please refer to our book 'Energy Unlimited' (available free of charge from Victron Energy and downloadable from [www.victronenergy.com](http://www.victronenergy.com)).

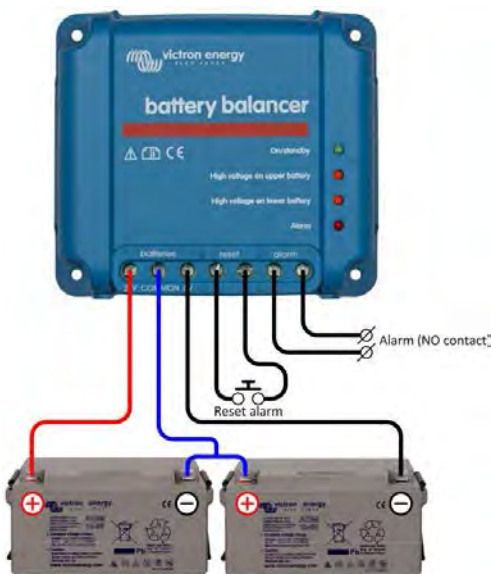

**Battery Balancer connected to two series connected 12 V batteries (24 V system)**

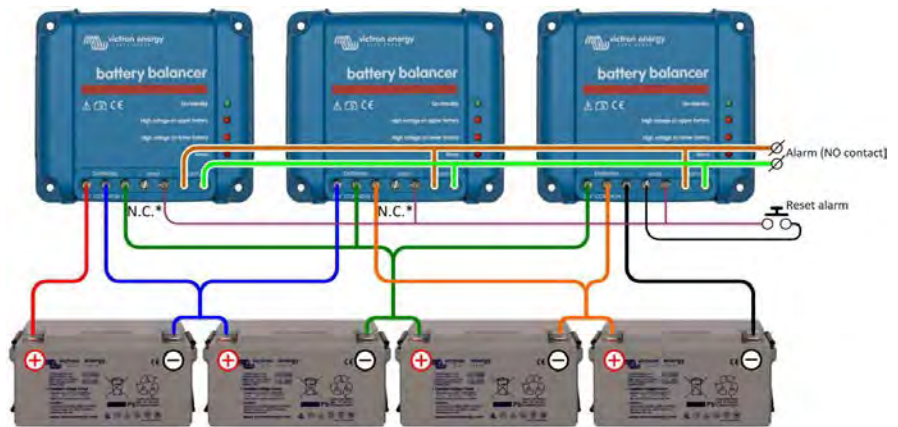

\* Do not connect this terminal. The left reset terminal should only be connected on the battery balancer nearest to system ground.

**Three Battery Balancers connected to four series connected 12 V batteries (48 V system)**

Victron Battery Balancer	
Input voltage range	Up to 18 V per battery, 36 V total
Turn on level	27,3 V +/- 1%
Turn off level	26,6 V +/- 1%
Current draw when off	0,7 mA
Midpoint deviation to start balancing	50 mV
Maximum balancing current	0,7 A (when deviation > 100 mV)
Alarm trigger level	200 mV
Alarm reset level	140 mV
Alarm relay	60 V / 1 A normally open
Alarm relay reset	Two terminals to connect a push button
Over temperature protection	yes
Operating temperature	-30 to +50°C
Humidity (non-condensing)	95%
ENCLOSURE	
Colour	Blue (RAL 5012)
Connection terminals	Screw terminals 6 mm <sup>2</sup> / AWG10
Protection category	IP22
Weight	0,4 kg
Dimensions (h x w x d)	100 x 113 x 47 mm
STANDARDS	
Safety	EN 60950
Emission	EN 61000-6-3, EN 55014-1
Immunity	EN 61000-6-2, EN 61000-6-1, EN 55014-2
Automotive Directive	EN 50498

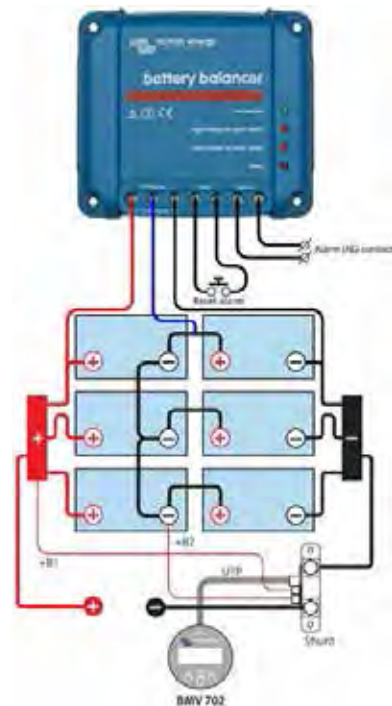

Battery Balancer connected to six series-parallel connected 12 V batteries (24 V system)

### Installation

- The Battery Balancer(s) must be installed on a well-ventilated vertical surface close to the batteries (but, due to possible corrosive gasses, not above the batteries!)
- In case of series-parallel connection, the midpoint interconnecting cables must be sized to at least carry the current that arises when one battery becomes open-circuited.**
  - In case of 2 parallel strings: cross section 50% of the series interconnecting cables.
  - In case of 3 parallel strings: cross section 33% of the series interconnecting cables, etc.
- If required: first wire the alarm contact and the alarm reset.
- Use at least 0,75 mm<sup>2</sup> to wire the negative, positive and midpoint connections (in this order).
- The balancer is operational.
  - When the voltage over a string of two batteries is less than 26,6 V the balancer switches to standby and all LEDs will be off.
  - When the voltage over a string of two batteries increases to more than 27,3 V (during charging) the green LED will turn on, indicating that the balancer is on.
  - When on, a voltage deviation of more than 50 mV will start the balancing process and at 100 mV one of the two orange LEDs will turn on. A deviation of more than 200 mV will trigger the alarm relay.

### What to do in case of an alarm during charging

In case of a new battery bank the alarm is probably due to differences in initial state-of-charge. If the difference between the lowest and highest battery voltage reading is more than 0,9 V: stop charging and charge the individual batteries or cells separately first, or reduce charge current substantially and allow the batteries to equalize over time.

- If the problem persists after several charge-discharge cycles:
- In case of series-parallel connection disconnect the midpoint parallel connection wiring and measure the individual midpoint voltages during absorption charge to isolate batteries or cells which need additional charging, or:
  - Charge and then test all batteries or cells individually or:
  - Connect two or more battery balancers in parallel (on average one balancer will take care of up to three parallel 200 Ah strings).

In case of an older battery bank which has performed well in the past, the problem may be due to:

- Systematic undercharge: more frequent charging needed (VRLA batteries), or equalization charge needed (flooded deep cycle flat plate or OPzS batteries). Better and regular charging will solve the problem.
- One or more faulty cells: replace all batteries.

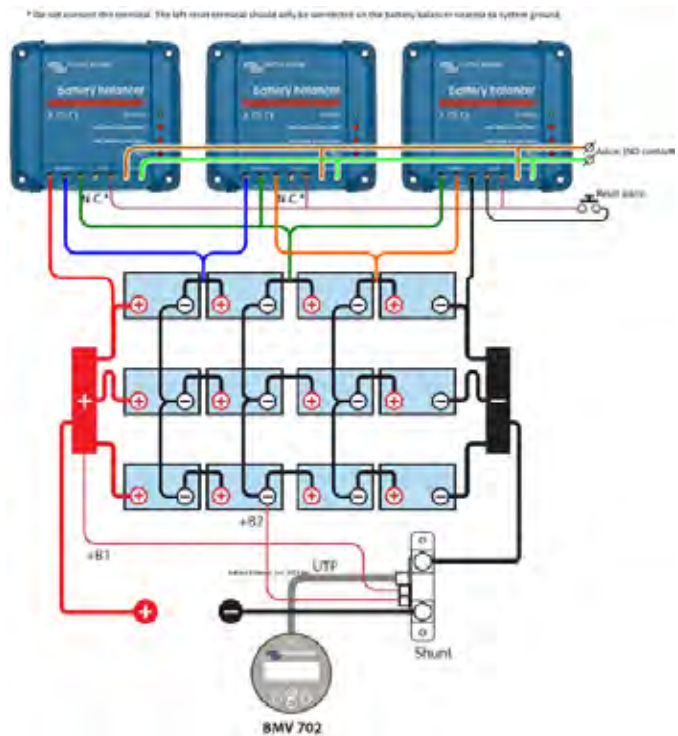

Three Battery Balancers connected to 12 series-parallel connected 12 V batteries (48 V system)





**Telecom Battery**  
**Battery AGM 12 V 200 Ah**

**Designed for telecom applications; excellent 'floor space savers' for marine and vehicle applications**

The deep cycle AGM telecom series has been designed for use in telecom systems. With front access terminals and small footprint, the batteries are ideal for racked systems. Similarly, these batteries can help solve limited floor space and access problems on board boats and vehicles.

**AGM technology**

AGM stands for Absorbent Glass Mat. In these batteries the electrolyte is absorbed into a glass-fibre mat between the plates by capillary action.

**Low self-discharge**

Because of the use of lead calcium grids and high purity materials, Victron VRLA batteries can be stored during long periods of time without recharge. The rate of self-discharge is less than 2% per month at 20°C. The self-discharge doubles for every increase in temperature with 10°C.

**Low internal resistance**

Accepts very high charge and discharge rates

**High cyclic life capability**

More than 500 cycles at 50% depth of discharge

**Learn more about batteries and battery charging**

To learn more about batteries and charging batteries, please refer to our book 'Energy Unlimited' (available free of charge from Victron Energy and downloadable from [www.victronenergy.com](http://www.victronenergy.com)).



**Telecom Battery**  
**Battery AGM 12 V 200 Ah**

12V AGM Telecom battery	115Ah	165Ah	200Ah
Capacity 1 / 3 / 5 / 10 / 20 hours (% of nominal)	60 / 75 / 82 / 91 / 100 (@ 70°F/25°C, end of discharge 10,5 V)		
Capacity 10 / 20 / 30 / 40 minutes (% of nominal)	33 / 44 / 53 / 57 (@ 70°F/25°C, end of discharge 9,6 V)		
Nominal capacity (77°F/25°C, 10,5 V)	115 Ah	165 Ah	200 Ah
Cold Cranking Amps @ 0°F/-18°C	1000	1500	1800
DIN cold start current (A) @ 0°F/-18°C	600	900	1000
Short Circuit Current (A)	3500	5000	6000
Reserve Capacity (minutes)	200	320	400
Shelf life @ 70°F/20°C	1 year		
Absorption voltage (V) @ 70°F/20°C	14,4 – 14,7		
Float voltage (V) @ 70°F/20°C	13,6 – 13,8		
Storage voltage (V) @ 70°F/20°C	13,2		
Float design life @ 70°F/20°C	12 years		
Cycle design life @ 100% discharge	250		
Cycle design life @ 50% discharge	500		
Cycle design life @ 30% discharge	1000		
Dimensions (l x w x h, mm)	395 x 110 x 293 mm	548 x 105 x 316 mm	546 x 125 x 323 mm
Dimensions (l x w x h, inches)	15.37 x 4.33 x 11.53	21.57 x 4.13 x 12.44	21.49 x 4.92 x 12.71
Weight (kg / pounds)	35 kg / 77 lbs	49 kg / 88 lbs	60 kg / 132 lbs



OPzS Solar Batteries 910

**Long life flooded tubular plate batteries**

Design life: >20 years at 20°C, >10 years at 30°C, >5 years at 40°C.  
 Cycling expectancy of up to 1500 cycles at 80% depth of discharge.  
 Manufactured according to DIN 40736, EN 60896 and IEC 61427.

**Low maintenance**

Under normal operating conditions and 20°C, distilled water has to be added every 2 - 3 years.

**Dry-charged or ready for use electrolyte filled**

The batteries are available filled with electrolyte or dry-charged (for long term stocking, container transport or air transport). Dry charged batteries have to be filled with diluted sulphuric acid (density 1,24 kg/l @ 20°C). The electrolyte may be stronger for cold- or weaker for hot climates.

**Learn more about batteries and battery charging**

To learn more about batteries and charging batteries, please refer to our book 'Energy Unlimited' (available free of charge from Victron Energy and downloadable from [www.victronenergy.com](http://www.victronenergy.com)).

OPzS Solar type	OPzS Solar 910	OPzS Solar 1210	OPzS Solar 1520	OPzS Solar 1830	OPzS Solar 2280	OPzS Solar 3040	OPzS Solar 3800	OPzS Solar 4560
Nominal capacity (120 hr / 20°C)	910 Ah	1210 Ah	1520 Ah	1830 Ah	2280 Ah	3040 Ah	3800 Ah	4560 Ah
Capacity (10 hr / 20°C)	640 Ah	853 Ah	1065 Ah	1278 Ah	1613 Ah	2143 Ah	2675 Ah	3208 Ah
Capacity 2 / 5 / 10 hours (% of 10 hr capacity)	60 / 85 / 100 (@ 68°F/20°C, end of discharge 1,8 Volt per cell)							
Capacity 20 / 24 / 48 / 72 hours (% of 120 hr capacity)	77 / 80 / 89 / 95 (@ 68°F/20°C, end of discharge 1,85 Volt per cell)							
Capacity 100 / 120 / 240 hours (% of 120 hr capacity)	99 / 100 / 104 (@ 68°F/20°C, end of discharge 1,85 Volt per cell)							
Self-discharge @ 70°F/20°C	3% per month							
Absorption voltage (V) @ 70°F/20°C	2,35 to 2,50 V/cell (28,2 to 30,0 V for a 24 Volt battery)							
Float voltage (V) @ 70°F/20°C	2,23 to 2,30 V/cell (26,8 to 27,6 V for a 24 Volt battery)							
Storage voltage (V) @ 70°F/20°C	2,18 to 2,22 V/cell (26,2 to 26,6 V for a 24 Volt battery)							
Float design life @ 70°F/20°C	20 years							
Cycle design life @ 80% discharge	1500							
Cycle design life @ 50% discharge	2800							
Cycle design life @ 30% discharge	5200							
Dimensions (l x w x h, mm)	145 x 206 x 711	210 x 191 x 711	210 x 233 x 711	210 x 275 x 711	210 x 275 x 861	212 x 397 x 837	212 x 487 x 837	212 x 576 x 837
Dimensions (l x w x h, inches)	5,7 x 8,1 x 28	8,3 x 7,5 x 28	8,3 x 9,2 x 28	8,3 x 10,8 x 28	8,3 x 10,8 x 33,9	8,4 x 15,6 x 32,9	8,4 x 19,2 x 32,9	8,4 x 22,7 x 32,9
Weight without acid (kg / pounds)	35 / 77	46 / 101	57 / 126	66 / 146	88 / 194	115 / 254	145 / 320	170 / 375
Weight with acid (kg / pounds)	50 / 110	65 / 143	80 / 177	93 / 205	119 / 262	160 / 253	200 / 441	240 / 530

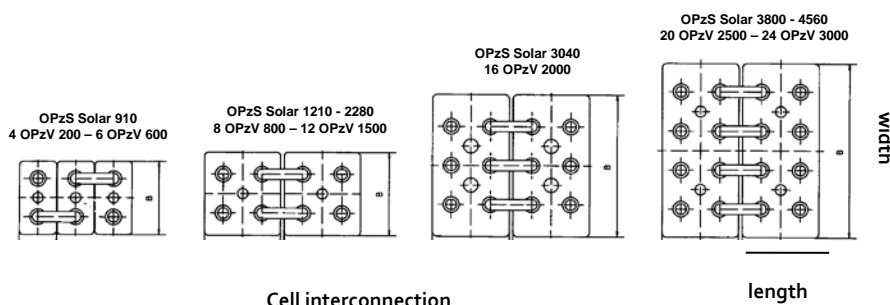

## Gel and AGM batteries



**AGM battery**  
12V 90Ah



**GEL OPzV 2V cell**

### 1. VRLA technology

VRLA stands for Valve Regulated Lead Acid, which means the batteries are sealed. Gas will escape through the safety valves only in case of overcharging or cell failure.

VRLA batteries are maintenance free for life.

### 2. Sealed (VRLA) AGM batteries

AGM stands for Absorbent Glass Mat. In these batteries the electrolyte is absorbed into a glass-fibre mat between the plates by capillary action. As explained in our book 'Energy Unlimited', AGM batteries are more suitable for short-time delivery of very high currents (engine starting) than gel batteries.

### 3. Sealed (VRLA) Gel batteries

Here the electrolyte is immobilized as gel. Gel batteries in general have a longer service life and better cycle capacity than AGM batteries.

### 4. Low Self-discharge

Because of the use of lead calcium grids and high purity materials, Victron VRLA batteries can be stored during long periods of time without recharge. The rate of self-discharge is less than 2% per month at 20°C. The self discharge doubles for every increase in temperature with 10°C.

Victron VRLA batteries can therefore be stored during up to a year without recharging, if kept under cool conditions.

### 5. Exceptional Deep Discharge Recovery

Victron VRLA batteries have exceptional discharge recovery, even after deep or prolonged discharge.

It should however be stressed that repetitive deep discharge and prolonged discharge have a very negative influence on the service life of all lead acid batteries, Victron batteries are no exception.

### 6. Battery discharging characteristics

The rated capacity of Victron AGM and Gel Deep Cycle batteries refers to 20 hour discharge, in other words: a discharge current of 0,05 C.

The rated capacity of Victron Tubular Plate Long Life batteries refers to 10 hours discharge.

The effective capacity decreases with increasing discharge current (see table 1). Please note that the capacity reduction will be even faster in case of a constant power load, such as an inverter.

Discharg time (constant current)	End Voltage V	AGM 'Deep Cycle' %	Gel 'Deep Cycle' %	Gel 'Long Life' %
20 hours	10,8	100	100	112
10 hours	10,8	92	87	100
5 hours	10,8	85	80	94
3 hours	10,8	78	73	79
1 hour	9,6	65	61	63
30 min.	9,6	55	51	45
15 min.	9,6	42	38	29
10 min.	9,6	38	34	21
5 min.	9,6	27	24	
5 seconds		8 C	7 C	

**Table 1: Effective capacity as a function of discharge time**  
(the lowest row gives the maximum allowable 5 seconds discharge current)

Our AGM deep cycle batteries have excellent high current performance and are therefore recommended for high current applications such as engine starting. Due to their construction, Gel batteries have a lower effective capacity at high discharge currents. On the other hand, Gel batteries have a longer service life, both under float and cycling conditions.

### 7. Effect of temperature on service life

High temperature has a very negative effect on service life. The service life of Victron batteries as a function of temperature is shown in table 2.

Average Temperature	AGM 'Deep Cycle' years	Gel 'Deep Cycle' years	Gel 'Long Life' years
20°C / 68°F	7 - 10	12	20
30°C / 86°F	4	6	10
40°C / 104°F	2	3	5

**Table 2: Design service life of Victron batteries under float service**



**8. Effect of temperature on capacity**

As is shown by the graph below, capacity reduces sharply at low temperatures.

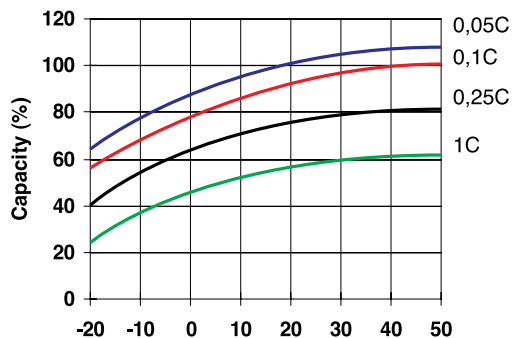

**Fig. 1: Effect of temperature on capacity**

**9. Cycle life of Victron batteries**

Batteries age due to discharging and recharging. The number of cycles depends on the depth of discharge, as is shown in figure 2.

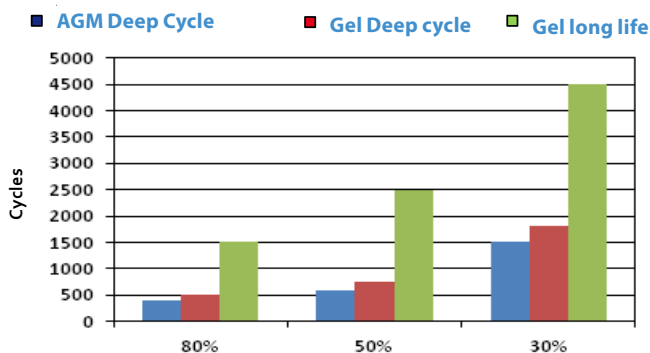

**Fig. 2: Cycle life** Depth of discharge

**10. Battery charging in case of cycle use: the 3-step charge curve**

The most common charge curve used to charge VRLA batteries in case of cyclic use is the 3-step charge curve, whereby a constant current phase (the bulk phase) is followed by two constant voltage phases (absorption and float), see fig. 3.

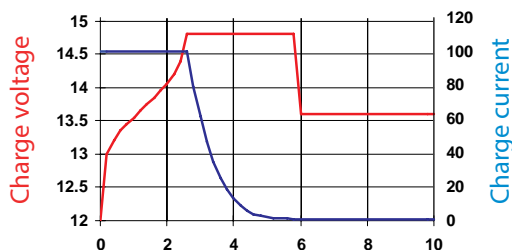

**Fig. 3: Three step charge curve**

During the absorption phase the charge voltage is kept at a relatively high level in order to fully recharge the battery within reasonable time. The third and last phase is the float phase: the voltage is lowered to standby level, sufficient to compensate for self discharge.

**Disadvantages of the traditional 3-step charge curve:**

- During the bulk phase the current is kept at a constant and often high level, even after the gassing voltage (14,34 V for a 12 V battery) has been exceeded. This can lead to excessive gas pressure in the battery. Some gas will escape through the safety valves, reducing service life.
- Thereafter the absorption voltage is applied during a fixed period of time, irrespective of how deep the battery has been discharged previously. A full absorption period after a shallow discharge will overcharge the battery, again reducing service life. (a.o. due to accelerated corrosion of the positive plates)
- Research has shown that battery life can be increased by decreasing float voltage to an even lower level when the battery is not in use.

**11. Battery charging: longer battery life with Victron 4-step adaptive charging**

Victron developed the adaptive charge curve. The 4-step adaptive charge curve is the result of years of research and testing.

**The Victron four-step adaptive charge curve solves the 3 main problems of the 3 step curve:**

- **Battery Safe Mode**  
In order to prevent excessive gassing, Victron has invented the 'Battery Safe Mode'. The Battery Safe Mode will limit the rate of voltage increase once the gassing voltage has been reached. Research has shown that this will reduce internal gassing to a safe level.
- **Variable absorption time**  
Based on the duration of the bulk stage, the charger calculates how long the absorption time should be in order to fully charge the battery. If the bulk time is short, this means the battery was already charged and the resulting absorption time will also be short, whereas a longer bulk time will also result in a longer absorption time.
- **Storage mode**  
After completion of the absorption period the battery should be fully charged, and the voltage is lowered to the float or standby level. If no discharge occurs during the next 24 hours, the voltage is reduced even further and the battery goes into storage mode. The lower storage voltage reduces corrosion of the positive plates. Once every week the charge voltage is increased to the absorption level for a short period to compensate for self discharge (Battery Refresh mode).

**12. Battery charging in case of standby use: constant voltage float charging**

When a battery is not frequently deeply discharged, a 2-step charge curve can be used. During the first phase the battery is charged with a limited current (the bulk phase). Once a preset voltage has been reached the battery is kept at that voltage (the float phase).

This charge method is used for starter batteries in vehicles and in uninterruptible power supplies (UPS).

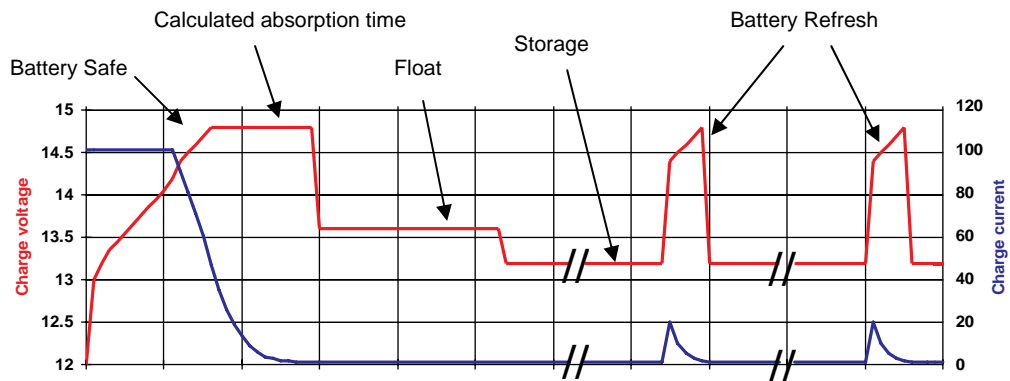

**Fig. 4: Four-step adaptive charge curve**

**13. Optimum charge voltage of Victron VRLA batteries**

The recommended charge voltage settings for a 12 V battery are shown in table 3.

**14. Effect of temperature on charging voltage**

The charge voltage should be reduced with increased temperature. Temperature compensation is required when the temperature of the battery is expected to be less than 10°C / 50°F or more than 30°C / 85°F during long periods of time.

The recommended temperature compensation for Victron VRLA batteries is -4 mV / Cell (-24 mV / °C for a 12 V battery).

The centre point for temperature compensation is 20°C / 70°F.

**15. Charge current**

The charge current should preferably not exceed 0,2 C (20 A for a 100 Ah battery). The temperature of a battery will increase by more than 10°C if the charge current exceeds 0,2 C. Therefore temperature compensation is required if the charge current exceeds 0,2 C.

	Float Service (V)	Cycle service Normal (V)	Cycle service Fastest recharge (V)
<b>Victron AGM 'Deep Cycle'</b>			
Absorption		14,2 - 14,6	14,6 - 14,9
Float	13,5 - 13,8	13,5 - 13,8	13,5 - 13,8
Storage	13,2 - 13,5	13,2 - 13,5	13,2 - 13,5
<b>Victron Gel 'Deep Cycle'</b>			
Absorption		14,1 - 14,4	
Float	13,5 - 13,8	13,5 - 13,8	
Storage	13,2 - 13,5	13,2 - 13,5	
<b>Victron Gel 'Long Life'</b>			
Absorption		14,0 - 14,2	
Float	13,5 - 13,8	13,5 - 13,8	
Storage	13,2 - 13,5	13,2 - 13,5	

Table 3: Recommended charge voltage

12 Volt Deep Cycle AGM							General Specification
Article number	Ah	V	l x w x h mm	Weight kg	CCA @0°F	RES CAP @80°F	Technology: flat plate AGM Terminals: copper
BAT406225080	240	6	320x176x247	31	1500	480	Rated capacity: 20 hr. discharge at 25°C Float design life: 7-10 years at 20°C Cycle design life: 400 cycles at 80% discharge 600 cycles at 50% discharge 1500 cycles at 30% discharge
BAT212070080	8	12	151x65x101	2,5			
BAT212120080	14	12	151x98x101	4,1			
BAT212200080	22	12	181x77x167	5,8			
BAT412350080	38	12	197x165x170	12,5			
BAT412550080	60	12	229x138x227	20	450	90	
BAT412600080	66	12	258x166x235	24	520	100	
BAT412800080	90	12	350x167x183	27	600	145	
BAT412101080	110	12	330x171x220	32	800	190	
BAT412121080	130	12	410x176x227	38	1000	230	
BAT412151080	165	12	485x172x240	47	1200	320	
BAT412201080	220	12	522x238x240	65	1400	440	

12 Volt Deep Cycle GEL							General Specification
Article number	Ah	V	l x w x h mm	Weight kg	CCA @0°F	RES CAP @80°F	Technology: flat plate GEL Terminals: copper
BAT412550100	60	12	229x138x227	20	300	80	Rated capacity: 20 hr. discharge at 25°C Float design life: 12 years at 20°C Cycle design life: 500 cycles at 80% discharge 750 cycles at 50% discharge 1800 cycles at 30% discharge
BAT412600100	66	12	258x166x235	24	360	90	
BAT412800100	90	12	350x167x183	26	420	130	
BAT412101100	110	12	330x171x220	33	550	180	
BAT412121100	130	12	410x176x227	38	700	230	
BAT412151100	165	12	485x172x240	48	850	320	
BAT412201100	220	12	522x238x240	66	1100	440	

2 Volt Long Life GEL					General Specification
Article number	Ah	V	l x b x h mm	Weight kg	Technology: tubular plate GEL Terminals: copper
BAT702601260	600	2	145x206x688	49	Rated capacity: 10 hr. discharge at 25°C Float design life: 20 years at 20°C Cycle design life: 1500 cycles at 80% discharge 2500 cycles at 50% discharge 4500 cycles at 30% discharge
BAT702801260	800	2	210x191x688	65	
BAT702102260	1000	2	210x233x690	80	
BAT702122260	1200	2	210x275x690	93	
BAT702152260	1500	2	210x275x840	115	
BAT702202260	2000	2	215x400x815	155	
BAT702252260	2500	2	215x490x815	200	
BAT702302260	3000	2	215x580x815	235	

Other capacities and terminal types: at request





**12,8 V 90 Ah LiFePO<sub>4</sub> Battery**  
LFP-CB 12,8/90  
(cell balancing only)



**12,8 V 90 Ah LiFePO<sub>4</sub> Battery**  
LFP-BMS 12,8/90  
(cell balancing and BMS interface)

## Why lithium-iron-phosphate?

Lithium-iron-phosphate (LiFePO<sub>4</sub> or LFP) is the safest of the mainstream li-ion battery types. The nominal voltage of a LFP cell is 3,2 V (lead-acid: 2V/cell). A 12,8 V LFP battery therefore consists of 4 cells connected in series; and a 25,6 V battery consists of 8 cells connected in series.

### Rugged

A lead-acid battery will fail prematurely due to sulfation:

- If it operates in deficit mode during long periods of time (i.e. if the battery is rarely, or never at all, fully charged).
- If it is left partially charged or worse, fully discharged (yacht or mobile home during wintertime).

A LFP battery does not need to be fully charged. Service life even slightly improves in case of partial charge instead of a full charge. This is a major advantage of LFP compared to lead-acid.

Other advantages are the wide operating temperature range, excellent cycling performance, low internal resistance and high efficiency (see below).

LFP is therefore the chemistry of choice for very demanding applications.

### Efficient

In several applications (especially off-grid solar and/or wind), energy efficiency can be of crucial importance. The round trip energy efficiency (discharge from 100% to 0% and back to 100% charged) of the average lead-acid battery is 80%.

The round trip energy efficiency of a LFP battery is 92%.

The charge process of lead-acid batteries becomes particularly inefficient when the 80% state of charge has been reached, resulting in efficiencies of 50% or even less in solar systems where several days of reserve energy is required (battery operating in 70% to 100% charged state).

In contrast, a LFP battery will still achieve 90% efficiency under shallow discharge conditions.

### Size and weight

Saves up to 70% in space

Saves up to 70% in weight

### Expensive?

LFP batteries are expensive when compared to lead-acid. But in demanding applications, the high initial cost will be more than compensated by longer service life, superior reliability and excellent efficiency.

### Endless flexibility

LFP batteries are easier to charge than lead-acid batteries. The charge voltage may vary from 14 V to 16 V (as long as no cell is subjected to more than 4,2 V), and they do not need to be fully charged. Therefore several batteries can be connected in parallel and no damage will occur if some batteries are less charged than others.

### With or without Battery Management System (BMS)?

Important facts:

1. A LFP cell will fail if the voltage over the cell falls to less than 2,5 V (note: recovery by charging with a low current, less than 0,1C, is sometimes possible).

2. A LFP cell will fail if the voltage over the cell increases to more than 4,2 V.

Lead-acid batteries will eventually also be damaged when discharged too deeply or overcharged, but not immediately. A lead-acid battery will recover from total discharge even after it has been left in discharged state during days or weeks (depending on battery type and brand).

3. The cells of a LFP battery do not auto-balance at the end of the charge cycle.

The cells in a battery are not 100% identical. Therefore, when cycled, some cells will be fully charged or discharged earlier than others. The differences will increase if the cells are not balanced/equalized from time to time.

In a lead-acid battery a small current will continue to flow even after one or more cells are fully charged (the main effect of this current is decomposition of water into hydrogen and oxygen). This current helps to fully charge other cells that are lagging behind, thus equalizing the charge state of all cells.

The current through a LFP cell however, when fully charged, is nearly zero, and lagging cells will therefore not be fully charged. Over time the differences between cells may become some so extreme that, even though the overall battery voltage is within limits, some cells will fail due to over- or under voltage. Cell balancing is therefore highly recommended.

In addition to cell balancing, a BMS will:

- Prevent cell under voltage by timely disconnecting the load.
- Prevent cell overvoltage by reducing charge current or stopping the charge process.
- Shut down the system in case of over temperature.

A BMS is therefore indispensable to prevent damage to large Li-ion battery banks.

**With cell balancing, but without BMS: 12,8 V LFP batteries for light duty applications**

In applications where excessive discharge (to less than 11 V), overcharge (to more than 15 V) or excessive charge current will never occur, 12,8 V batteries with cell balancing only may be used.

Please note that these batteries are not suitable for series or parallel connection.

Notes:

1. A Battery Protect module (see [www.victronenergy.com](http://www.victronenergy.com)) may be used to prevent excessive discharge.
2. The current draw of inverters and inverterchargers is often still significant (0,1 A or more) after low voltage shutdown. The remaining standby current will therefore damage the battery if the inverters or inverterchargers are left connected to the battery after low voltage shutdown during a long period of time.

**With cell balancing and interface to connect to a Victron BMS: 12,8 V LFP batteries for heavy duty applications and parallel/series connection**

These batteries have integrated Cell Balancing, Temperature and Voltage control (BTv). Up to ten batteries can be paralleled and up to four batteries can be series connected (BTvs are simply daisy-chained) so that a 48 V battery bank of up to 2000 Ah can be assembled. The daisy-chained BTvs must be connected to a Battery Management System (BMS).

**Battery Management System (BMS)**

The BMS connects to the BTvs and its essential functions are:

1. Disconnect or shut down the load whenever the voltage of a battery cell falls to less than 2,5 V.
2. Stop the charging process whenever the voltage of a battery cell increases to more than 4,2 V.
3. Shut down the system whenever the temperature of a cell exceeds 50°C.

More features may be included: see the individual BMS datasheets.

Battery specification								
	Cell balancing only				Cell balancing and BMS interface			
VOLTAGE AND CAPACITY	LFP-CB 12,8/60	LFP-CB 12,8/90	LFP-CB 12,8/160	LFP-CB 12,8/200	LFP-BMS 12,8/60	LFP-BMS 12,8/90	LFP-BMS 12,8/160	LFP-BMS 12,8/200
Nominal voltage	12,8 V	12,8 V	12,8 V	12,8 V	12,8 V	12,8 V	12,8 V	12,8 V
Nominal capacity @ 25°C*	60 Ah	90 Ah	160 Ah	200 Ah	60 Ah	90 Ah	160 Ah	200 Ah
Nominal capacity @ 0°C*	48 Ah	72 Ah	130 Ah	160 Ah	48 Ah	72 Ah	130 Ah	160 Ah
Nominal capacity @ -20°C*	30 Ah	45 Ah	80 Ah	100 Ah	30 Ah	45 Ah	80 Ah	100 Ah
Nominal energy @ 25°C*	768 Wh	1152 Wh	2048 Wh	2560 Wh	768 Wh	1152 Wh	2048 Wh	2560 Wh
*Discharge current ≤1C								
CYCLE LIFE								
80% DoD	2500 cycles							
70% DoD	3000 cycles							
50% DoD	5000 cycles							
DISCHARGE								
Maximum continuous discharge current	180 A	270 A	400 A	500 A	180 A	270 A	400 A	500 A
Recommended continuous discharge current	≤60 A	≤90 A	≤160 A	≤200 A	≤60 A	≤90 A	≤160 A	≤200 A
Maximum 10 s pulse current	600 A	900 A	1200 A	1500 A	600 A	900 A	1200 A	1500 A
End of discharge voltage	11 V	11 V	11 V	11 V	11 V	11 V	11 V	11 V
OPERATING CONDITIONS								
Operating temperature	-20°C to +50°C (maximum charge current when battery temperature < 0°C: 0,05°C, i.e. 10 A in case of a 200 Ah battery)							
Storage temperature	-45°C to +70°C							
Humidity (non-condensing)	Max. 95%							
Protection class	IP 54							
CHARGE								
Charge voltage	Between 14 V and 15 V (<14,5 V recommended)							
Float voltage	13,6 V							
Maximum charge current	60 A	90 A	160 A	200 A	180 A	270 A	400 A	500 A
Recommended charge current	≤20 A	≤25 A	≤40 A	≤50 A	≤30 A	≤45 A	≤80 A	≤100 A
OTHER								
Max storage time @ 25°C*	1 year							
BMS connection	n. a.				Male + female cable with M8 circular connector, length 50 cm			
Power connection (threaded inserts)	M8	M8	M10	M10	M8	M8	M10	M10
Dimensions (hxxwxd) mm	235x293x139	249x293x168	320x338x233	295x425x274	235x293x139	249x293x168	320x338x233	295x425x274
Weight	12 kg	16 kg	33 kg	42 kg	12 kg	16 kg	33 kg	42 kg
*When fully charged								

**VE.Bus BMS**

### Protects each individual cell of a Victron lithium iron phosphate (LiFePO<sub>4</sub> or LFP) battery

Each individual cell of a LiFePO<sub>4</sub> battery must be protected against over voltage, under voltage and over temperature.

Victron LiFePO<sub>4</sub> batteries have integrated Balancing, Temperature and Voltage control (acronym: BTV) and connect to the VE.Bus BMS with two M8 circular connector cord sets.

The BTV's of several batteries can be daisy chained. Up to ten batteries can be paralleled and up to four batteries can be series connected (BTV's are simply daisy-chained) so that a 48 V battery bank of up to 2000Ah can be assembled. Please see our LiFePO<sub>4</sub> battery documentation for details.

The BMS will:

- shut down or disconnect loads in case of imminent cell under voltage,
- reduce charge current in case of imminent cell overvoltage or over temperature (VE.Bus products only, see below), and
- shut down or disconnect battery chargers in case of imminent cell overvoltage or over temperature.

### Protects 12 V, 24 V and 48 V systems

Operating voltage range of the BMS: 9 to 70 V DC.

### Communicates with all VE.Bus products

The VE.Bus BMS connects to a MultiPlus, Quattro or Phoenix inverter with a standard RJ45 UTP cable.

Other products, without VE.Bus can be controlled as shown below:

#### Load Disconnect

The Load Disconnect output is normally high and becomes free floating in case of imminent cell under voltage. Maximum current: 2 A.

The Load Disconnect output can be used to control

- the remote on/off of a load, and/or
- the remote on/off of an electronic load switch (Battery Protect) and/or
- a Cyrix-Li-load relay.

#### Charge Disconnect

The Charge Disconnect output is normally high and becomes free floating in case of imminent cell over voltage or over temperature. Maximum current: 10 mA.

The Charge Disconnect output can be used to control

- the remote on/off of a charger and/or
- a Cyrix-Li-Charge relay and/or
- a Cyrix-Li-ct Battery Combiner.

#### LED indicators

- **Enabled (blue):** VE.Bus products are enabled.
- **Cell>4V or temperature (red):** charge disconnect output low because of imminent cell over voltage or over temperature.
- **Cell>2,8V (blue):** load disconnect output high.

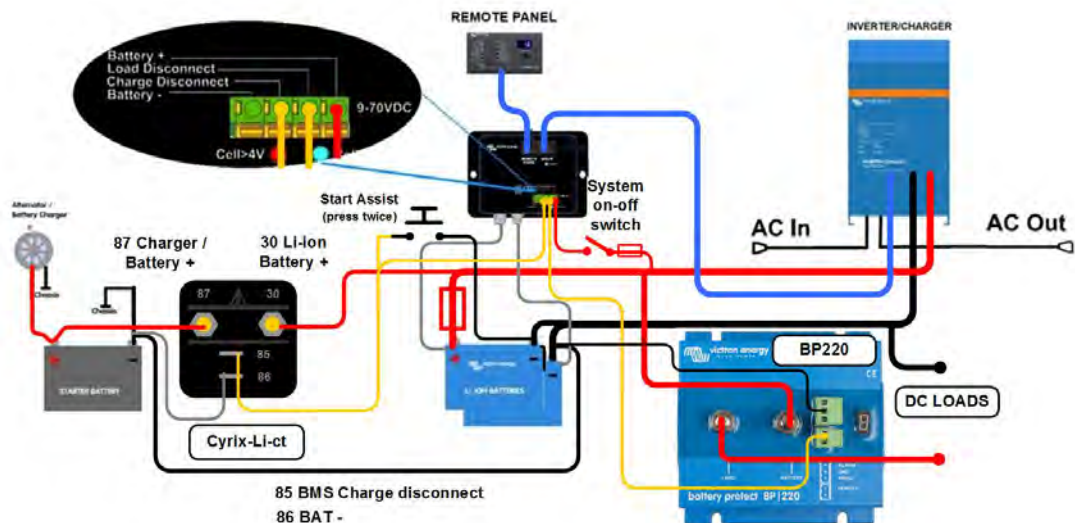

Figure 1: Application example for a vehicle or boat.

A Cyrix Li-ion Battery Combiner is used to connect to the starter battery and alternator.

The UTP cable to the inverter/charger also provides the minus connection to the BMS.

VE.Bus BMS	
Input voltage range	9 – 70 VDC
Current draw, normal operation	10 mA (excluding Load Disconnect current)
Current draw, low cell voltage	2 mA
Load Disconnect output	Normally high Source current limit: 2 A Sink current: 0 A (output free floating)
Charge Disconnect output	Normally high Source current limit: 10 mA Sink current: 0 A (output free floating)
GENERAL	
VE.Bus communication port	Two RJ45 sockets to connect to all VE.Bus products
Operating temperature	-20 to +50°C 0 - 120°F
Humidity	Max. 95% (non condensing)
Protection grade	IP20
ENCLOSURE	
Material and color	ABS, matt black
Weight	0,1 kg
Dimensions (hwxwd)	105 x 78 x 32 mm
STANDARDS	
Standards: Safety Emission Immunity Automotive	EN 60950 EN 61000-6-3, EN 55014-1 EN 61000-6-2, EN61000-6-1, EN 55014-2 Regulation UN/ECE-R10 Rev.4

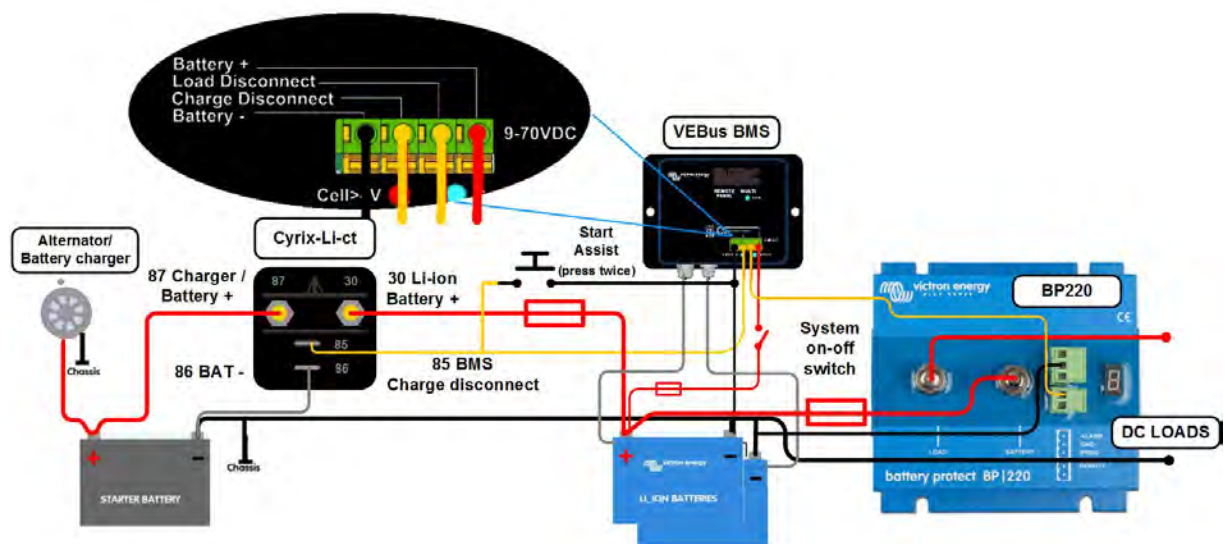

Figure 2: Application example for a vehicle or boat, without inverter/charger.

**Six Cyrix Combiners especially designed for use with the VE.Bus BMS:**

**Cyrix-Li-load (120A or 230A)**

The Cyrix-Li-Load will prevent frequent switching when a low cell voltage is followed by a higher voltage after loads have been switched off.

Note: instead of a Cyrix-Li-Load, a BatteryProtect may also be used (see figure 2).

**Cyrix-Li-ct (120A or 230A)**

A battery combiner with a Li-ion adapted engage/disengage profile and a control terminal to connect to the Charge Disconnect of the BMS.

**Cyrix-Li-Charge (120A or 230A)**

A unidirectional combiner to insert in between a battery charger and the LFP battery. It will engage only when charge voltage from a battery charger is present on its charge-side terminal. A control terminal connects to the Charge Disconnect of the BMS.





## 24V 180Ah Lithium-ion battery and Lynx-ion



24 V 180 Ah Lithium-Ion Battery



Lynx Ion



Ion control: Main screen



Ion control: History screen



Ion control: Lynx Ion Status

### The advantages of a Lithium-ion battery over conventional lead-acid batteries

- High energy density: more energy with less weight;
- High charge currents (shortens the charge period);
- High discharge currents (enabling for example electrical cooking on a small battery bank);
- Long battery life (up to six times the battery life of a conventional battery);
- High efficiency between charging and discharging (very little energy loss due to heat development);
- Higher continuous power available.

### Why Lithium-Iron-Phosphate?

Lithium-Iron-Phosphate (LiFePO<sub>4</sub> or LFP) is the safest of the mainstream Li-ion battery types. The nominal voltage of a LFP cell is 3,2 V (lead-acid: 2 V / cell). A 25,6 V LFP battery consists of 8 cells connected in series.

### The advantages of the Victron Lynx Lithium-ion battery system

The modular system used adds below advantages:

- The Victron Lithium-Ion Battery System is easy to install due to its modularity. No complicated wiring diagrams are required.
- Detailed information is available on the waterproof Ion Control display.
- The 350 A relay in the Lynx-Ion provides maximum safety: in case the chargers or loads do not listen to the commands from the Lynx-Ion, the main safety relay will open to prevent permanent damage to the batteries.
- For typical marine installations there is an extra smaller output, so you can still power the bilge pump and disconnect all other house loads by opening the 350 A relay.

### Complete system

A complete system consists of:

- One or more **24 V 180 Ah Lithium-Ion batteries**.
- (optional) The **Lynx Power In**, a modular dc bus bar.
- The **Lynx Ion** is the battery management system (BMS) that controls the batteries. A 350 Ampère safety contactor is inside the Lynx Ion.
- The **Lynx Shunt VE.Can**, a battery monitor including the main fuse. Note that the fuse needs to be purchased separately.
- (optional) The **Lynx Distributor**, a DC distribution system with fuses.
- (optional) The **Ion Control**, a digital control panel.

### 24 V 180 Ah Lithium-Ion Batteries

The base of the Victron Lithium-Ion Battery System is formed by individual 24 V / 180 Ah Lithium-ion batteries. They have a built-in Cell Management System (BMS) which protects the battery on a cell level. It monitors individual cell voltage and system temperature, and actively balances the individual cells. All measured parameters are sent to the Lynx Ion which monitors the system as a whole.

### Lynx Ion

The Lynx Ion is the BMS. It contains the 350 A safety contactor, and controls the cell-balancing, charging and discharging of the system. The Lynx Ion will protect the battery pack from both overcharging and depletion. When an overcharge is imminent, it will signal the charging devices to decrease or stop charging. This is done with the VE.Can bus (NMEA2000) compatible, and also via the two available open/close contacts. Same when the battery is nearing empty, and there is no charging capability available. It will signal big loads to switch off.

For both overcharging and depletion there is a last safety resort, the built-in 350 A contactor. In case signalling etcetera does not stop the imminent overcharge or depletion, it will open the contactor.

### NMEA2000 Canbus

Communication with the outside world is done via the VE.Can protocol.

### Ion Control

See the separate [Ion Control](#) datasheet for more information on the display.

Lithium-ion 24 V 180 Ah 4.75 kWh battery	
Technology	Lithium iron phosphate (LiFePo <sub>4</sub> )
Nominal voltage	26,4 V
Nominal capacity	180 Ah
Nominal power	4,75 kWh
Weight	55 kg
Power/Weight ratio	86 Wh/kg
Dimensions (l x w x h)	625 x 195 x 355 mm
Charge cut-off voltage at 0.05C	28,8 V
Discharge cut-off voltage	20 V
Recommended charge/discharge current	54 A (0,3C)
Maximum charge current (1C)	180 A
Maximum discharge current (1.5C)	270 A
Pulse discharge current (10s)	1000 A
Cycle Life @80% DOD (0.3C)	2000
Series configuration	Yes, up to 2 (more in series on request)
Parallel configuration	Yes, easy up to 4 (more parallel on request)
Operating temp. charge	0~45°C
Operating temp. discharge	-20~55°C
Storage temp.	-20~45°C

Lynx Ion	
Maximum number batteries in series	2
Maximum number batteries in parallel	8
Enclosure	
Weight	1,4 kg
Dimensions (l x w x h)	190 x 180 x 80 mm
IO	
Safety contactor	350 A
Bilge pump contactor maximum current	10 A
External relay contactor maximum current	10 A
Charged-signal contact	1 A @ 60 VDC
Discharged-signal contact	1 A @ 60 VDC
Standards	
Emission	EN 50081-1
Immunity	EN 50082-1

Block diagram Lithium-Ion Battery System

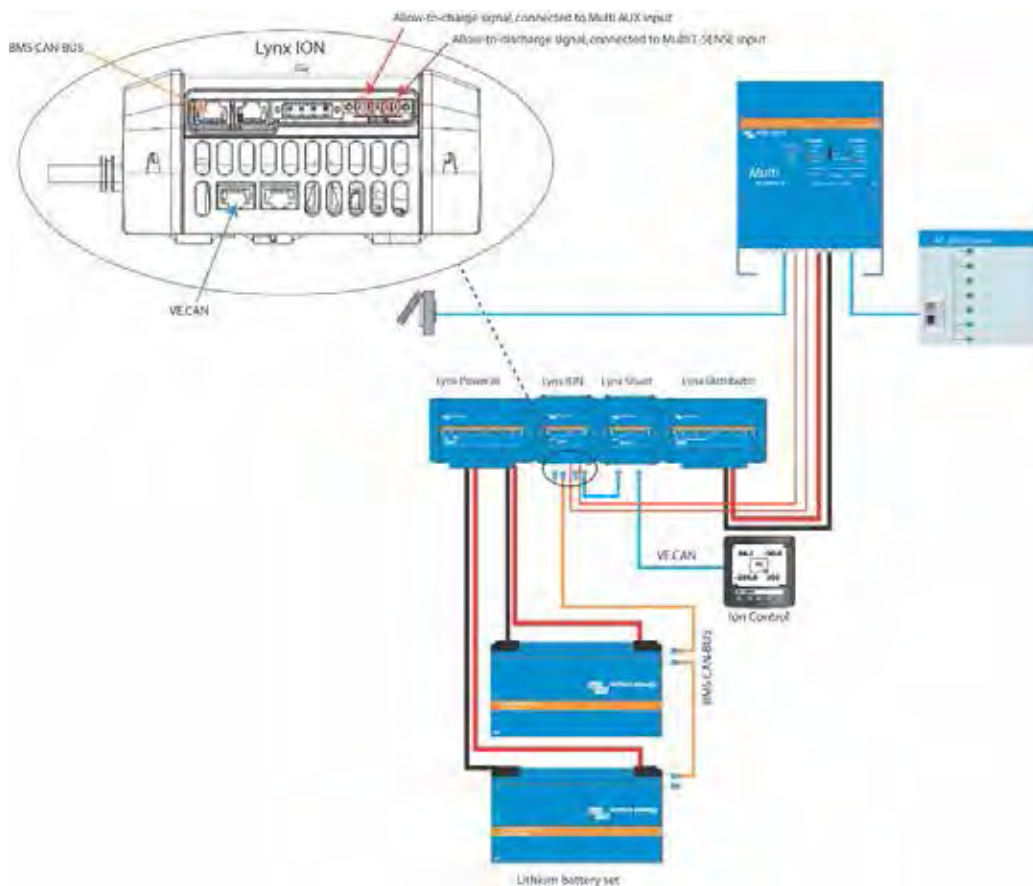

## Victron Energy hakkında

40 yıldan fazla tecrübeye sahip Victron Energy teknik inovasyon, güvenilirlik ve kalite konusunda rakipsiz bir üne sahip. Victron kendi kendini yeten elektrik gücü tedarikinde dünya lideridir. Ürünlerimiz, çeşitli zanaat, eğlence, ticaret faaliyetlerinde ve benzeri alanlarda karşılaşılan en zorlu durumların gereksinimlerini karşılayacak şekilde tasarlanmıştır. Victron'un özel şebekeden bağımsız sistem taleplerini karşılama becerisi benzersizdir. Ürün çeşitlerimiz arasında sinüs dalgalı invertörler, invertör/şarj cihazları, akü şarj cihazları, DC/DC konvertörler, aktarma anahtarları, Jel ve AGM aküler, alternatörler, akü monitörleri, güneş enerjili şarj regülatörleri, Solar Paneller, komple ağ çözümleri ve diğer birçok yenilikçi çözüm bulunmaktadır.

### **Dünya çapında servis ve destek**

Hem ticari, hem de boş zaman deniz sektörlerine, bağımsız şebeke, araç ve sanayi piyasalarına 40 yıldır hizmet veren Victron'un bütün dünyada oturmuş bir satıcı ve bayi ağı mevcuttur. Müşteri tabanımız için anında ve yetkin yerel servis sağlamak çok önemlidir.

Bu durum da destek ağımızın kapasitelerinde kendisini gösterir. Servis desteğine olan esnek yaklaşımımız ve onarımlar için hızlı dönüşüme gösterdiğimiz gayret, piyasada lider konumdadır. En zorlu uygulamalarda onlarca yıldır güvenilir servis sağlayan Victron ürünlerinin sayısız örnekleri mevcuttur. Bu güvenilirlik seviyesiyle birlikte azami düzeyde teknik bilgi, Victron Energy güç sistemlerinin mevcut en iyi değeri sunduğunun bir göstergesidir.







Solar panels of Himalayan hotel, Corbis





SAL064132080  
REV 01  
2015-12



**Victron Energy B.V.**

De Paal 35 • 1351JG Almere • The Netherlands

Phone: +31 (0)36 535 97 00 • Fax: +31 (0)36 535 97 40 • E-mail: [sales@victronenergy.com](mailto:sales@victronenergy.com)

[www.victronenergy.com](http://www.victronenergy.com)

